

POWER RAIL 323

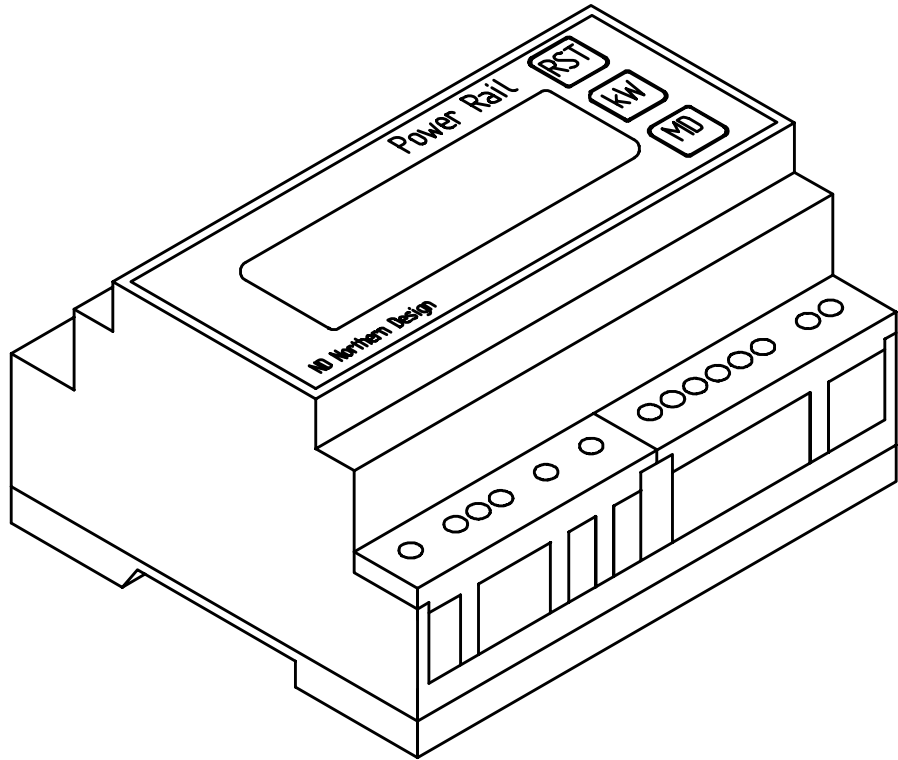

Installation and Operation

PREFACE

<p>Power Rail Operating Guide Revision 1.05 February 2002</p>
--

This manual represents your meter as manufactured at the time of publication. It assumes standard software. Special versions of software may be fitted, in which case you will be provided with additional details.

Every effort has been made to ensure that the information in this manual is complete and accurate. We revised this manual but cannot be held responsible for errors or omissions.

The apparatus has been designed and tested in accordance with EN 61010, 'Safety Requirements for Electrical Equipment for Measurement, Control and Laboratory Use'. This operating guide contains information and warnings, which must be followed by the user to ensure safe operation and to maintain the apparatus in a safe condition.

We reserve the right to make changes and improvements to the product without obligation to incorporate these changes and improvements into units previously shipped.

General Editor : Ian Sykes BSc (hons).

Copyright © 2002 : Northern Design (Electronics) Ltd,
228 Bolton Road, Bradford. West Yorkshire. UK.

Table Of Contents

1. SAFETY	5
1.1 WARNING SYMBOLS.....	5
1.2 MAINTENANCE.....	5
2. METER OPERATION	6
2.1 MEASUREMENTS	6
2.1.1 <i>Power (kW)</i>	6
2.1.2 <i>Examples of Display Scaling</i>	7
2.1.3 <i>Energy (kWh)</i>	8
2.1.4 <i>Rolling Demand (kW MD)</i>	8
2.2 DISPLAY PAGES	10
2.3 kWh RESET	11
2.4 PEAK DEMAND RESET.....	11
2.5 RESET DISABLE.....	12
2.6 ISOLATED PULSE OUTPUT	13
2.6.1 <i>Connecting The Pulse Output</i>	13
3. INSTALLATION	14
3.1 RAIL MOUNTING	14
3.2 CT CONNECTIONS (I1-I3)	14
3.3 VOLTAGE CONNECTIONS (VN, V1-V3)	15
3.4 AUXILIARY MAINS SUPPLY (L & N).....	15
3.5 CONNECTION SCHEMATICS.....	16
4. PROGRAMMING	19
4.1 DESCRIPTION	19
4.2 ENTERING PROGRAMMING MODE.....	19
4.3 SETTING THE CT PRIMARY CURRENT	19
4.4 SETTING THE SCALING FACTOR.....	20
4.5 SETTING THE PULSE OUTPUT RATE	21
4.6 SETTING THE MD TIME PERIOD.....	22

5. OPTIONS MODULE	25
5.1 DESCRIPTION	25
5.2 MOUNTING THE OPTIONS UNIT	26
5.3 AUXILIARY MAINS SUPPLY	27
5.4 OPERATION.....	28
5.5 DUAL ANALOGUE OUTPUTS	29
5.6 ANALOGUE OUTPUT CONNECTION	30
5.6.1 <i>Internal Circuit</i>	30
5.6.2 <i>Loop Powered Connection</i>	31
5.6.3 <i>Internally Powered Connection</i>	32
5.7 MODBUS COMMUNICATIONS	33
5.7.1 <i>Communication Address</i>	33
5.7.2 <i>Data Format</i>	33
5.7.3 <i>RS485</i>	34
5.7.4 <i>RS422</i>	36
5.8 MODBUS™ PROTOCOL	38
5.8.1 <i>An Introduction To Modbus™</i>	38
5.8.2 <i>RTU. Transmission Mode</i>	39
5.8.3 <i>Power Rail Data Tables</i>	44
5.8.4 <i>RTU Commands</i>	49
5.8.5 <i>Function 04 Read Multiple Registers</i>	49
5.8.6 <i>Function 06 Preset a Single Register</i>	51
5.8.7 <i>Function 08 Loop Back Diagnostic</i>	53
5.8.8 <i>Function 16 Preset Multiple Registers</i>	55
5.8.9 <i>Exception Responses</i>	57
5.9 MODBUS™ DIAGNOSTICS LEDs	59
6. SPECIFICATION	60
6.1 POWER RAIL	60
6.2 OPTIONS MODULE	63

1. Safety

1.1 Warning Symbols

This manual provides details of safe installation and operation of the meter. Safety may be impaired if the instructions are not followed. Labels on individual meters give details of equipment ratings for safe operation. Take time to examine all labels on the meter and to read this manual before commencing installation.



Caution
Refer to User Instructions



Danger
Risk of Electric Shock

Figure 1.1 Safety Symbols

WARNING

The meter contains no user serviceable parts. Installation and commissioning should be carried out by qualified personnel

1.2 Maintenance

The equipment should be maintained in good working order. Damage to the product should be repaired by the manufacturer. The meter may be cleaned by wiping lightly with a soft cloth. No solvents or cleaning agents should be used. All inputs and supplies must be isolated before cleaning any other part of the equipment.

2. Meter Operation

2.1 Measurements

Power Rail measurements are based on a precision analogue kW transducer which detects true power over a wide input range. The analogue approach ensures accurate readings of all loads including electronically controlled types containing harmonics, burst fired elements, and those, which are unstable due to load variations.

The meter monitors instantaneous kW as its prime parameter. Other values such as kWh, kW Demand etc. are derived from this. Derived parameters are calculated in a microprocessor programmed specifically for the task of precision power/energy measurement. The microprocessor uses the kW transducer output, scaling factors and a precision crystal clock to determine and display the resulting measurements.

2.1.1 Power (kW)

Instantaneous kW is derived from the output of the kW transducer multiplied by two user programmable constants, ***CT Primary*** and ***Scaling Factor***.

These constants allow the user to configure the meter for use in a variety of systems detecting loads from a few watts to megawatts. The displayed values and all outputs from the Power Rail take these constants into account providing conveniently scaled values with decimal points and legends as required.

The decimal point position and legend (W, kW or MW) are automatically selected dependant on the scaling constants and nominal input voltage for the meter. The display is set for optimum resolution in the range 0-19999 (4½ digits). The setting takes into account maximum input signals, which may be larger than the nominal ratings for the meter.

2.1.2 Examples of Display Scaling

Meter Inputs : 3-Ph Power Rail, 230V (LN), 200:5A CT
User Settings : CT Primary = 200A, Scaling Factor = 1.0
Nominal kW : $230 \times 3 \times 200 \times 1.0 = 138 \text{ kW}$
+ 20% Over-range : $138 \text{ kW} \times 120\% = 165.6 \text{ kW}$
Optimum Display : Must be $< 19999 = 16560$
Power Rail Display : 0.00 kW - 165.60 kW

Meter Inputs : 3-Ph Power Rail, 230V (LN), 75:5A CT
User Settings : CT Primary = 750A, Scaling Factor = 0.1
Nominal kW : $230 \times 3 \times 750 \times 0.1 = 51.75 \text{ kW}$
+ 20% Over-range : $51.75 \text{ kW} \times 120\% = 62.1 \text{ kW}$
Optimum Display : Must be $< 19999 = 6210$
Power Rail Display : 0.00 kW - 62.10 kW

Meter Inputs : 3-Ph Power Rail, VT 4000:400V (LL), 2000:1A CT
User Settings : CT Primary = 2000A, Scaling Factor = 10.0
Nominal kW : $4000 \times \sqrt{3} \times 2000 = 13.86 \text{ MW}$
+ 20% Over-range : $13.86 \text{ MW} \times 120\% = 16.632 \text{ MW}$
Optimum Display : Must be $< 19999 = 16632$
Power Rail Display : 0.000 MW - 16.632 MW

Meter Inputs : 3-Ph Power Rail, VT 40,000:400V (LL), 2000:5A CT
User Settings : CT Primary = 2000A, Scaling Factor = 100.0
Nominal kW : $40,000 \times \sqrt{3} \times 2000 = 138.6 \text{ MW}$
+ 20% Over-range : $138.6 \text{ MW} \times 120\% = 166.32 \text{ MW}$
Optimum Display : Must be $< 19999 = 16632$
Power Rail Display : 0.00 MW - 166.32 MW

Meter Operation

2.1.3 Energy (kWh)

The kWh values are derived from the scaled kW readings, integrated over time, which is measured by a precision crystal controlled time-base.

Energy is displayed as a 7-digit accumulating register (counter), which is displayed with a decimal point and legend (Wh, kWh or MWh) for direct reading.

Scaling of kWh is derived from the scaling of kW with 1 less digit of resolution. For example if the kW display is in the range 0.00 kW - 62.10 kW the energy display will be in the range 0.0 kWh - 999999.9 kWh.

Automatic scaling of kWh in this way provides optimum resolution of display (and pulse outputs) with a reasonable time to roll over of the accumulating register.

On power failure or brownout the kWh register is automatically saved in non-volatile memory within the Power Rail. The memory requires no battery and will hold the value for up to 10 years in the absence of mains power.

2.1.4 Rolling Demand (kW MD)

This parameter provides an average of the scaled kW readings taken over a user programmable time period (1 - 60 Minutes). The display shows the average for the most recent time period ending at the time the display was last updated. The demand period is continuously updated as time progresses hence the term "**Rolling Demand**".

Scaling of Rolling Demand displays is identical to display of kW.

2.1.4.1 Calculating Rolling Demand

Each time period is split into 15 smaller sub-periods. The average of all kW readings taken by the meter during a sub-period is calculated ($\sum kW / N$) and stored in the meters memory. The latest sub-period average is stored in place of the oldest reading thus providing an array of the 15 most recent values. The average of the 15 most recent sub-period values is displayed as kW MD (rolling demand).

On power up (or after a brown-out) the 15 sub-period values are reset to zero. During the first full MD period the Rolling Demand value will accumulate as the zeroes are replaced with valid average kW readings.

2.1.4.2 Peak Demand (kW PK)

This parameter is the maximum recorded value of Rolling Demand kW.

This value may be used to determine the maximum load requirement of a system. This value is often used to determine spare capacity in a supply system, supply plant requirement etc. Scaling of Peak Demand displays is identical to display of kW.

On power failure or brownout the Peak Demand is automatically saved in non-volatile memory within the Power Rail. The memory requires no battery and will hold the value for up to 10 years in the absence of mains power.

Meter Operation

2.2 Display Pages

Information provided by the Power Rail is displayed on a two-line custom liquid crystal display (LCD). Two display pages are available in normal operating mode. The first page displays kW and kWh values updated each second. This page is accessed by pressing the **kW** key. The top line shows a direct reading of scaled kW and the bottom line the kWh accumulating register.



Figure 2.1 Typical Page 1 Display

The second page displays Rolling and Peak Demand updated at the end of each sub period as described above.

This page is accessed by pressing the **MD** key.

The top line shows Peak Demand and the bottom line the Average Demand for the most recent time period.

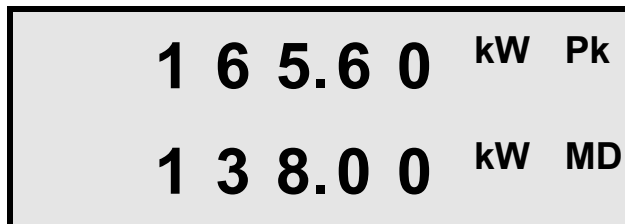

Figure 2.2 Typical Page 2 Display

2.3 kWh Reset

The kWh accumulating register may be reset to zero using the front panel keys. Once reset the energy reading is lost forever so great care must be taken when using this feature.

To reset the kWh register **Press** **RST** and **kW** keys **together and Hold for 5 seconds** until the kWh display shows zero.

2.4 Peak Demand Reset

The Peak Demand kW value may be reset to zero using the front panel keys. Once reset the Peak value is lost forever so great care must be taken when using this feature.

To reset the Peak Demand Value **Press** **RST** and **MD** keys **together and Hold for 1 second** until the Peak Demand display shows zero.

The accumulating demand and all values in the sub-period array (see 2.1.4.1) are also reset to zero. On reset Rolling Demand will accumulate over the first period until a full set of sub-period reading are obtained.

Meter Operation

2.5 Reset Disable

It is possible to disable the  key to prevent unauthorised or accidental access to reset features provided by the Power Rail.

To disable operation of the  key :

1. Isolate **ALL** power / inputs to the meter
2. Remove the front panel by prizing gently in the recess at the centre of either end using a flat screwdriver or similar tool.
3. Remove the “**RESET ENABLE**” Link. The link may be stored on a single pin if required at a later date.
4. Replace the front cover ensuring that it is fully seated.

WARNING RISK OF ELECTRIC SHOCK

Fully Isolate ALL inputs before removing the front panel
The front panel should only be removed by qualified personnel.

2.6 Isolated Pulse Output

A single isolated output is provided as standard on the Power Rail. The pulse output provides a volt free contact pair closure for a programmable number of increments (1, 10, 100 or 1000) of the kWh register. (e.g. 1 pulse per 10 kWh). The signal provided is designed as an input to building management systems, data collectors, remote counters etc.

On completion of the programmed number of counts the Pulse Output terminals momentarily appear short circuit (100ms). At all other times the pins appear open circuit.

The Pulse Output terminals are isolated (@ 2.5kV) from all other parts of the Power Rail circuit providing safe connection to external systems.

Each pulse output is indicated on the front panel of the Power Rail by a single flash of the  LED.

2.6.1 Connecting The Pulse Output

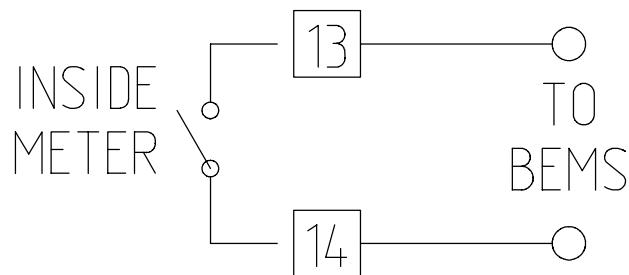

Figure 2.3 Pulse Output Connection

3. Installation

3.1 Rail Mounting

The Power Rail is housed in an enclosure conforming to DIN standard 43880, 6 Modules wide (106mm). The unit is therefore compatible with a number of standard DIN distribution systems with 45mm cut-outs. The unit may be mounted by itself or alongside other standard units such as timers, circuit breakers etc. The Power Rail should be mounted on a symmetric 35mm DIN rail of minimum length 106mm.

3.2 CT Connections (I1-I3)

The Power Rail is designed for use with current transformers (CTs). Recommended types should conform to Class 1 per IEC 185. The secondary of the CT should be specified to suit the input rating defined on the meter label. Cables used for the current circuit should have a maximum conductor size of 4.0mm² and should be kept as short as possible to reduce cable losses loading the CT secondary.

CT Inputs to the meter are isolated from each other and all other parts of the circuit. This allows use on a wide variety of systems including those requiring common and/or earthed CT secondaries.

WARNING

NEVER leave the secondary of a current transformer open circuit while a primary current flows. In this condition dangerous voltages may be produced at the secondary terminals.

3.3 Voltage Connections (Vn, V1-V3)

Cables used for the voltage measurement circuit should be insulated to a minimum of 600V AC and have a minimum current rating of 250mA. The maximum conductor size is 4.0mm².

External protection fuses are recommended for the voltage measurement inputs. These should be rated at 160mA maximum, Type F, and should be able to withstand voltages greater than the maximum input to the meter.

3.4 Auxiliary Mains Supply (L & N)

The Power Rail uses an isolated auxiliary mains supply separate from the voltage measurement inputs. This may be connected separately or in parallel with the measurement inputs providing the ratings detailed on the instrument label are not exceeded.

Separate connection of the auxiliary mains is required, for example, when :

- A suitable supply voltage is not available locally.
- Measurement voltages are expected to vary over a wide range
- A backup supply is required to maintain meter display

The auxiliary mains supply is internally fused at 230V, 100mA type T. External fusing is required if the auxiliary supply voltage exceeds 230V. The meter ratings are detailed on the instrument label.

WARNING

CHECK the instrument **LABELS** for correct input ratings.
Incorrectly rated inputs may permanently damage the device

Installation

3.5 Connection Schematics

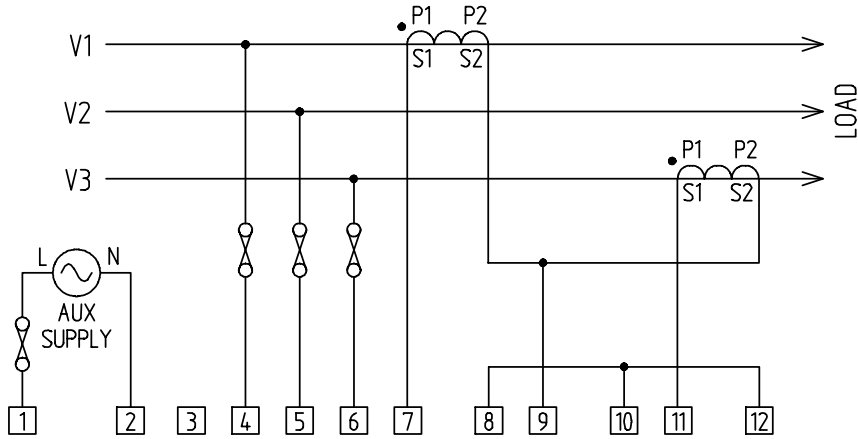

Figure 3.1 3-Phase 3-Wire (2CTs)

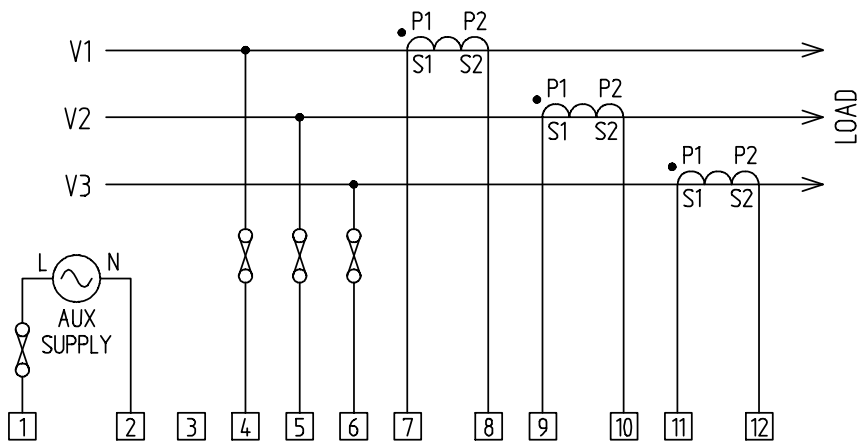

Figure 3.2 3-Phase 3-Wire (3CTs)

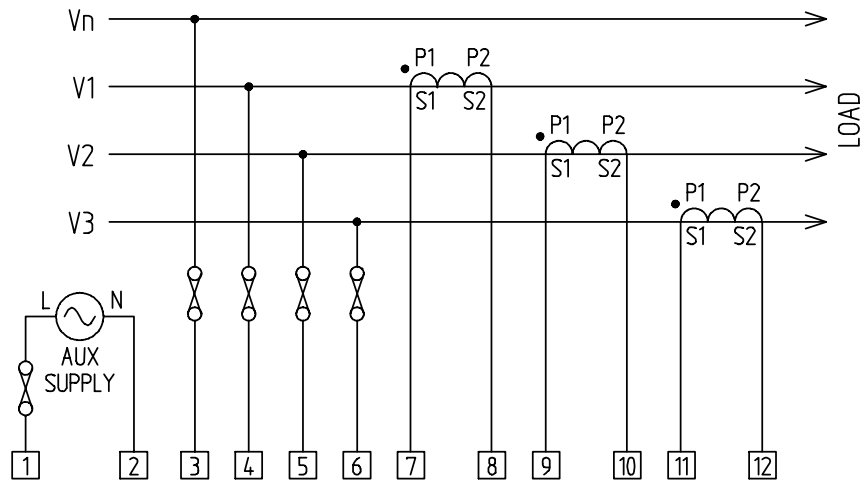

Figure 3.3 3-Phase 4-Wire

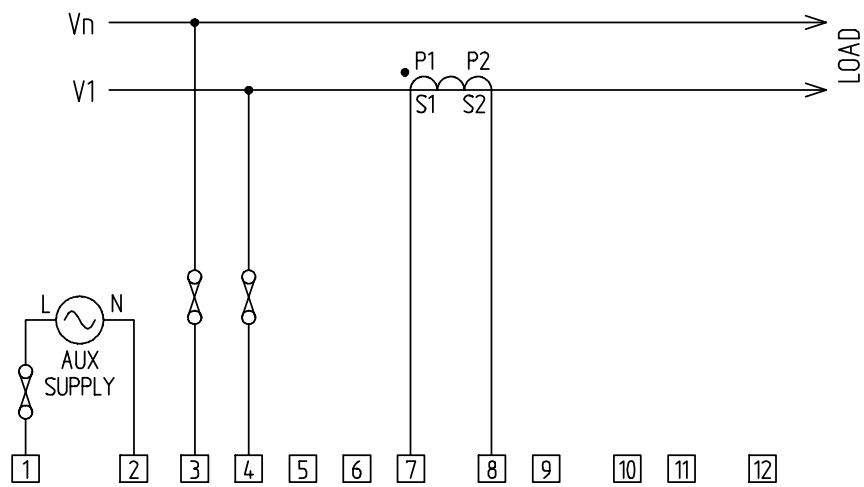

Figure 3.4 Single Phase

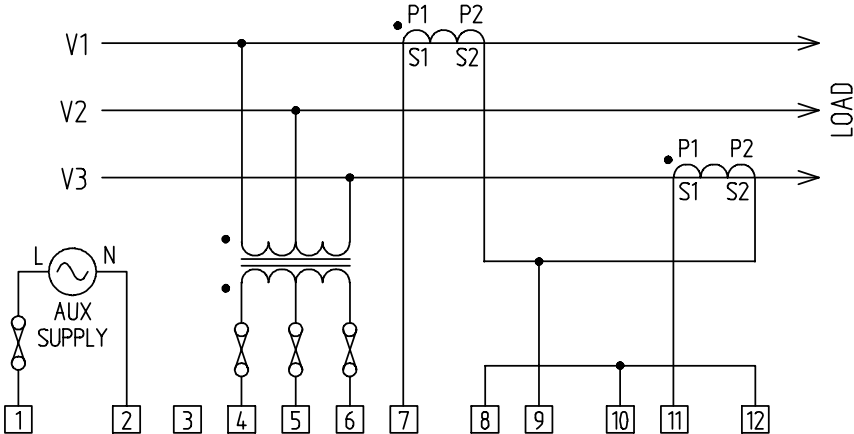

Figure 3.5 3 Phase 3 Wire Using Potential Transformers

4. Programming

4.1 Description

The Power Rail is designed for use in a wide variety of systems. A range of programmable features allow the unit to be set-up for a specific application. Programming is available using the front panel keypad and display while the unit is operational.

4.2 Entering Programming Mode

To enter programming Press \triangle and ∇ together and hold for 5 seconds.

4.3 Setting The CT Primary Current

The first item in the programming menu allows the user to set the CT Primary current, in the range 10A to 2000A (steps of 10), to match the current transformers connected to the meter inputs. Once set the constant acts as a multiplying factor in the internal calculation of all measurements.

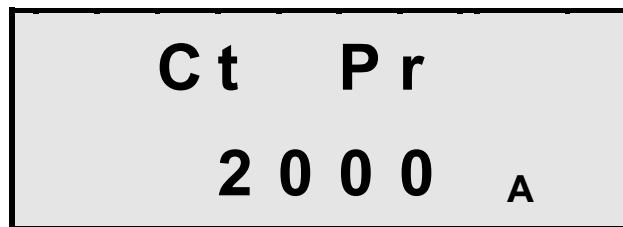

Figure 4.1 Setting The CT Primary Constant

Press \triangle to increase the CT Primary Constant in steps of 10 Amps.

Press ∇ to decrease the CT Primary Constant in steps of 10 Amps.

Press \triangle and ∇ together and hold for 3 seconds when done

.

Programming

4.4 Setting The Scaling Factor

The next item in the programming menu allows the user to set an additional multiplying factor (0.1, 1.0, 10.0, 100.0 or 1000.0) used in the internal calculation of all measurements.

This is useful if the Power Rail is connected to HV systems using measurement Voltage Transformers (VTs) or to select CT Primary values not programmable using the above procedure.

Example :

The Power Rail is connected via 200A CTs and 11,000V : 110V VTs.
Set CT Primary = 200A. Set Scale = 100

Example :

The Power Rail is connected via 25A CTs.
Set CT Primary = 250A. Set Scale = 0.1



Figure 4.2 Setting The Scaling Factor Constant

Press \triangle to increase the Scaling Constant by a factor of 10.

Press ∇ to decrease the Scaling Constant by a factor of 10.

Press \triangle and ∇ together and hold for 3 seconds when done

4.5 Setting The Pulse Output Rate

The Power Rail may be set to provide a single pulse at the end of every 1, 10, 100 or 1000 increments of the kWh register. This allows the unit to be configured to suit a wide variety of data logging, building management type applications.

During programming, the Pulse Output Rate is displayed scaled as kWh for convenience. A display of **PULSE 100.0 kWh** indicates that a single pulse will occur at the end of each 100 kWh.



Figure 4.3 Setting The Pulse Output Rate

Press \triangle to increase the Pulse Output Rate by a factor of 10.

Press ∇ to decrease the Pulse Output Rate by a factor of 10.

Press \triangle and ∇ together and hold for 3 seconds when done

4.6 Setting The MD Time Period

Rolling Demand and Peak Demand are average values measured over a given time period (Ref. 2.1.4.1). The time period used may be set, in the range 1-60 minutes, to suit a variety of applications or tariff arrangements.



Figure 4.4 Setting The MD Time Period

Press \triangle to increase the Time Period in steps of 1 minute.

Press ∇ to decrease the Time Period in steps of 1 minute.

Press \triangle and ∇ together and hold for 3 seconds when done

4.7 Setting The Baud Rate

The next item in the programming menu is only available when a Modbus Communications option module is fitted (refer to Section 5). This allows the user to set the baud rate for external Modbus serial communications. The user may select 4800, 9600 or 19200 baud to suit the external system.

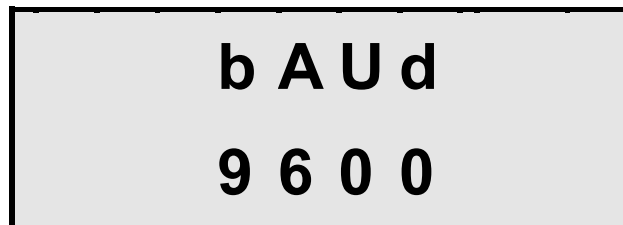

Figure 4.5 Setting The Modbus Baud Rate

Press \triangle to increase the baud rate.

Press ∇ to decrease the baud rate.

Press \triangle and ∇ together and hold for 3 seconds when done

Programming

4.8 Setting The Modbus Address

The next item in the programming menu is only available when a Modbus Communications option module is fitted (refer to Section 5). This allows the user to set the Address (ID) for external Modbus serial communications. The user may program addresses in the range 1-247 to uniquely identify each meter on a Modbus system.

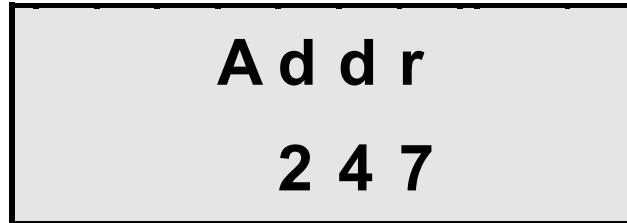

Figure 4.6 Setting The Modbus Address (ID)

Press \triangle to increment the Address.

Press ∇ to decrement the Address.

Press \triangle and ∇ together and hold for 3 seconds when done

5. Options Module

5.1 Description

An options module unit is available for use with the standard Power Rail meter. This provides Modbus serial communications and dual analogue outputs to external systems. The unit may be retrofitted to a previously installed meter.

The Options Module accesses Power Rail readings and program settings via a port on the side of the meter. This port provides an isolated interface between the meter and options outputs allowing safe connection to external systems. The Options Module not only reads the values via the port but may alter them if required.

The Options Unit is housed in an enclosure conforming to DIN standard 43880, 4 Modules wide (71mm). The unit is therefore compatible with a number of standard DIN distribution systems with 45mm cut-outs. The Options Unit should be mounted alongside a Power Rail on a symmetric 35mm DIN rail of minimum length 177mm.

Options Module

5.2 Mounting The Options Unit

To connect the Options Module to the Power Rail :

1. Isolate **All** inputs/outputs to the Power Rail.
2. Clip the Options Module onto the DIN Rail to the left of the Power Rail
3. Slide the Options Unit along the rail until it butts up to the Power Rail ensuring the Options Unit plug mates correctly with the Power Rail socket.

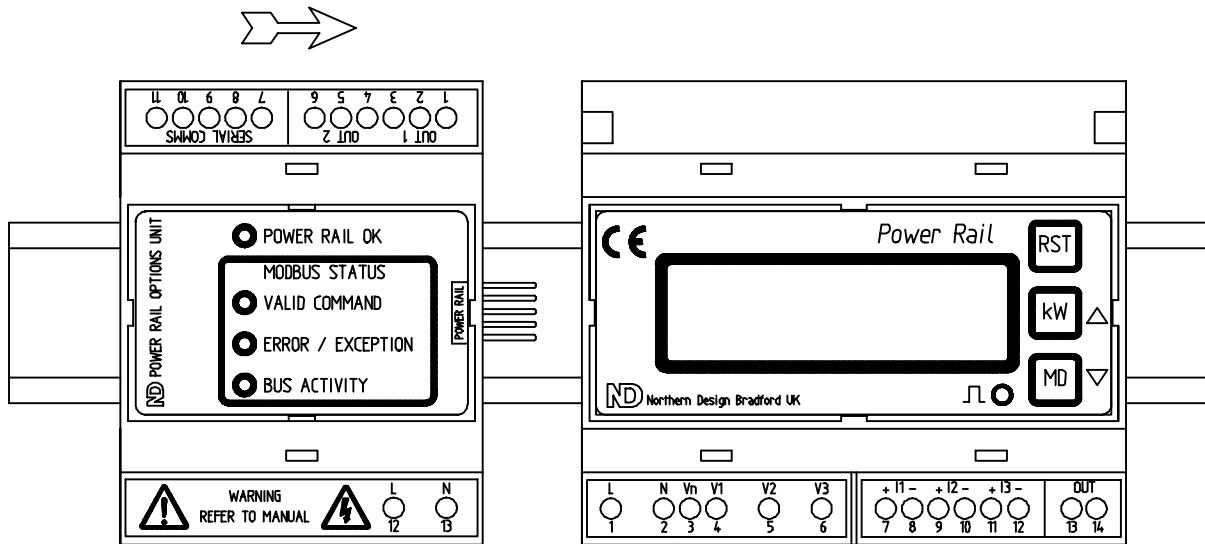

Figure 5.1 Options Module And Power Rail

5.3 Auxiliary Mains Supply

The Options Module requires a separate auxiliary mains input in order to maintain safety isolation from Power Rail measurement inputs. This may be wired in parallel with the Power Rail auxiliary mains input if the two units are rated equally.

The auxiliary mains supply is internally fused at 230V, 100mA type T. External fusing is required if the auxiliary supply voltage exceeds 230V. The meter ratings are detailed on the instrument label.

WARNING

CHECK the instrument **LABELS** for correct input ratings. Incorrectly rated inputs may permanently damage the device

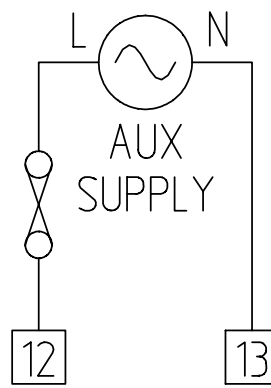

Figure 5.2 Options Module Auxiliary Mains Input

Options Module

5.4 Operation

Once connected and powered up the Power Rail and Options Unit will begin local communications with each other automatically. All readings taken by the meter are sent to the Options Module each second along with all meter program settings. The Options Module replies with confirmation of the values and any requests to alter meter settings.

The Options Module will confirm that it is receiving valid data from the Power Rail by illuminating the '**Power Rail OK**' LED. If for any reason the local communications fails this LED will switch off.

The Power Rail programming menu will automatically expand to include Modbus™ Baud Rate and Address settings when a valid Options Module is detected.

5.5 Dual Analogue Outputs

The Options Unit provides two isolated analogue outputs proportional to readings taken from the attached meter. The outputs are suitable for connection to chart recorders, building management systems, data loggers etc. 4-20mA current loop systems are used where remote analogue signals are required. Distances up to 1km may be achieved using quality screened twisted pair signal cable.

Output 1 is calibrated to give 4-20mA corresponding to 0-FS kW. Output 2 is calibrated to give 4-20mA corresponding to 0-FS Rolling Average kW.

The outputs are internally powered and isolated at 2.5kV from the attached meter and the Options Unit auxiliary mains input.

Full scale kW (and Average kW) is defined as :

$$\begin{aligned} & V_{LN} \times 3 \times CT \text{ Primary} \times \text{Scaling Factor} \\ \text{or} & V_{LL} \times \sqrt{3} \times CT \text{ Primary} \times \text{Scaling Factor} \end{aligned}$$

The kW output is updated each second in accordance with the meter's measurement cycle time.

The Average kW output is updated every $(T \times 60) / 15$ seconds, where T is the user setting of Rolling Demand time period in minutes (Ref. 4.6). This update is synchronous with the meters display of Rolling Average kW.

If no meter is attached the analogue outputs will measure 4mA.

Options Module

5.6 Analogue Output Connection

5.6.1 Internal Circuit

Each analogue output channel acts as a variable current sink to 0V. The current may be drawn from an external dc supply (15V - 30V) in a loop powered system or from the meters isolated V+ (18V dc).

The following schematic shows an equivalent internal circuit for each channel of the meter.

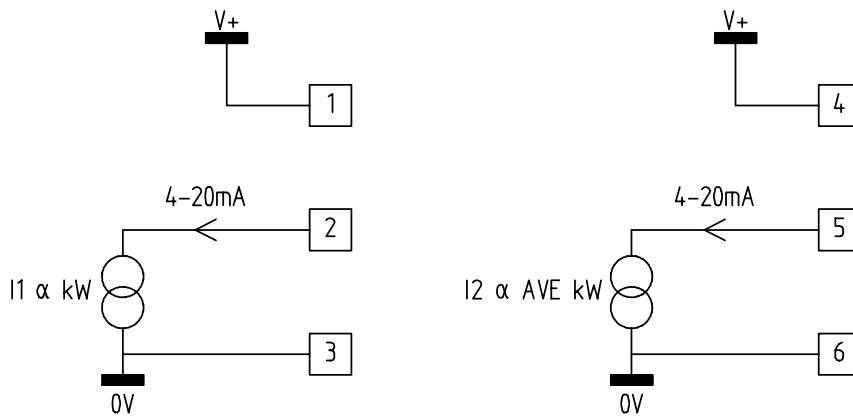

Figure 5.3 Options Unit Internal Circuit

5.6.2 Loop Powered Connection

Many external systems which utilise standard 4-20mA inputs provide a remote dc supply for the measurement loop current. The external system usually contains a sense resistor which produces a measurement voltage as shown in the connection diagram below.

The external supply must be sufficient to provide a dc voltage in the range 15-30V at the Options Unit terminals.

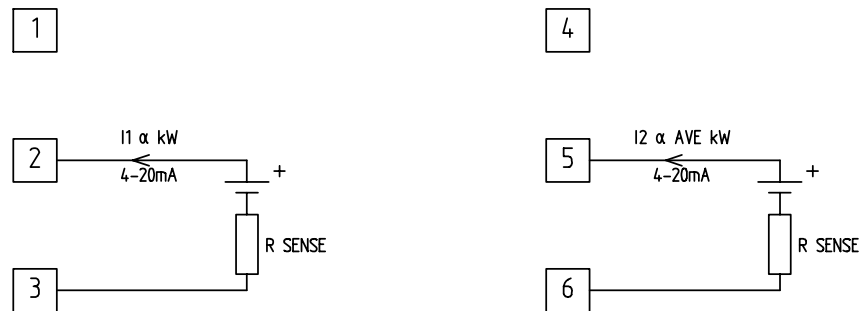

Figure 5.4 Analogue Output Connections (Loop Powered)

Options Module

5.6.3 Internally Powered Connection

The Options Unit provides an isolated DC supply as part of its analogue output system. This supply is rated at 18V, 45mA, sufficient to drive current into both analogue outputs. An external sense resistor (or milli-ammeter) may be used to provide a local voltage signal proportional to the output current.

R_{SENSE} values should be selected in the range 0-250 Ω which gives voltages of 1-5V at full scale (20mA).

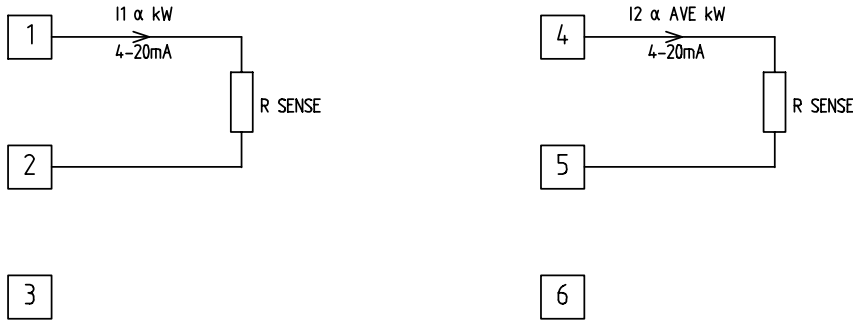

Figure 5.5 Analogue Output Connections (Internally Powered)

5.7 Modbus Communications

The Power Rail Options Module provides a serial communications interface to external systems. This allows remote reading and programming of the meter by a host computer (e.g. PC). The output may be wired as RS422 (full duplex) or RS485 (half duplex).

The communication protocol used by the Power Rail Options Module is a subset of Modicon's Modbus™ enabling use of standard off the shelf software packages and connection to standard controllers.

5.7.1 Communication Address

Each meter on a Modbus serial communication network must be assigned a unique address between 1 and 247. This is carried out in programming mode as described in Section 4. If two or more meters, connected in a multi-drop network have the same address, data on the network will be corrupted and communication will fail.

5.7.2 Data Format

The meter uses a fixed data format for serial communications :

1 Start Bit	8 Data Bits	1 Stop Bit
-------------	-------------	------------

The 8 data bits are always transmitted least significant bit first. This data byte is binary coded.

The baud rate is programmable as **4800, 9600, or 19200 baud**. This is carried out in programming mode as described in Section 4.

Options Module

5.7.3 RS485

The RS485 communication option enables connection of up to 128 meters on a single pair of wires (247 with repeaters). The pair is used for transmission and reception with each meter (and the host) automatically switching data direction. The host should be fitted with an RS485 driver (or converter) capable of operation in two wire mode (half duplex).

PC operation in RS485 two wire mode usually requires software control of the data direction. This controls the line drivers connected to the bus at the host serial port. This direction control requires high speed operation and may be problematic under certain operating systems such as Windows. It is advisable to check with the software vendor before selecting RS485 as the mode of operation.

If software data direction control is not suitable RS232-RS485 converters are available for standard PCs which carry out automatic hardware control. For more information on these contact your distributor.

Each Modbus serial transaction is preceded by a meter address allowing the host to temporarily connect with any meter on the bus. Certain commands allow the host to transmit commands or data to all meters simultaneously. These commands are known as **broadcasts** and use address 0. The RS485 standard enables reliable communication over a maximum distance of 1200 metres.

Standard line repeaters may be installed to increase the maximum distance of an RS485 network and/or the number of meters which may be connected.

5.7.3.1 RS485 Connection

It is recommended that screened twisted-pair cable is used for RS485 connection in order to minimise signal errors due to noise. An optional third wire, connecting the common (0V) at each unit, is recommended for optimum performance. The cable screen should be connected to the connector housing (ground) at the host only. To reduce cable reflections over long distances, RS422/485 systems require line termination. This is achieved by fitting two 120Ω terminating resistors as shown in Figure 5.6. One resistor should be fitted at the Host receive input buffer and the other at the receive buffer of the most remote meter.

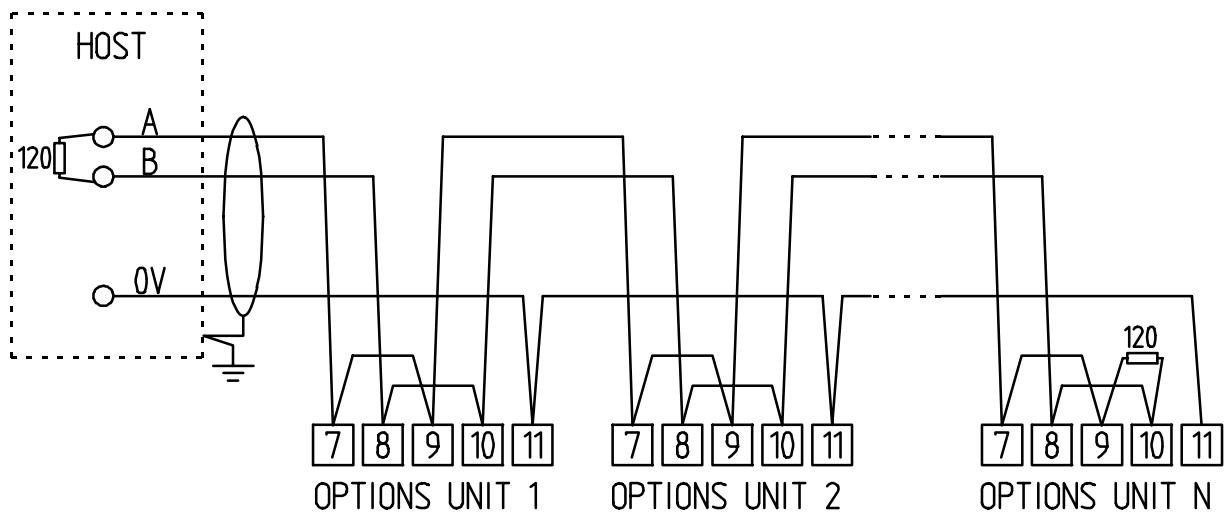

Figure 5.6 RS485 Multi-Drop Connection

Options Module

5.7.4 RS422

The RS422 communication option enables connection of up to 128 meters (247 with repeaters) on two pairs of wires (4-wire bus). One pair is used for transmission and the other for reception.

This connection is more commonly used in full duplex communications systems where host and slave can simultaneously transmit/receive data. In this instance however, the Modbus protocol itself ensures half duplex operation by default. RS422 may be used in systems where the host is not capable of operation in RS485 mode with data direction control. The RS422 standard enables reliable communication over a maximum distance of 1200 metres.

Standard line repeaters may be installed to increase the maximum distance of an RS422 network and/or the number of meters which may be connected.

5.7.4.1 RS422 Connection

It is recommended that screened 2 x twisted pair cable is used for RS422 connection in order to minimise signal errors due to noise. . An optional fifth wire, connecting the common (0V) at each unit, is recommended for optimum performance. The first pair should be used for RXA & RXB and the second for TXA & TXB. The screen should be connected to the connector housing (ground) at the host only. To reduce cable reflections over long distances, RS422 systems require line termination. This is achieved by fitting two 120Ω terminating resistors as shown in Figure 5.7. One resistor should be fitted at the Host receive input buffer and the other at the receive buffer of the most remote meter.

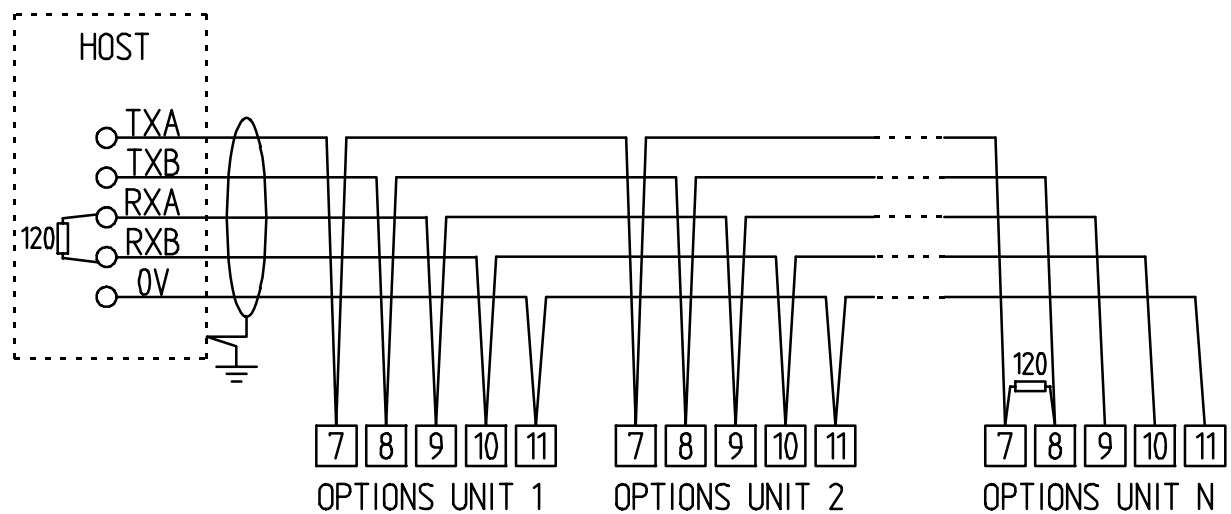

Figure 5.7 RS422 Multi-Drop Connection

Options Module

5.8 Modbus Protocol

5.8.1 An Introduction To Modbus

A communication protocol defines a set of commands and data formats which will be recognised by all compatible equipment connected on a system. The protocol effectively forms a communication language.

The Power Rail Options Units utilise a subset of Modicon's 'Modbus' standard protocol. This protocol was originally developed for use by programmable logic controllers (PLCs). It defines a set of commands for reading and/or writing data to devices connected on the bus.

Modbus is a master-slave protocol with all transactions initiated by a single host (e.g. a PC). A single transaction commences with the host transmission of a command packet followed by a slave (meter) reply within 20ms of the end of the transmitted message.

Command packets consist of an address, a command identifier, data and a checksum for error detection. Each slave device continually monitors the bus looking for activity. Command packets are detected by all slaves but may be acted upon only by the device whose address matches that transmitted.

The host may transmit a **broadcast command** which uses address 0 to contact all devices on the network. In this instance the command is acted upon by all slaves but none of them may reply. This type of command may be useful, for example, in synchronising energy register reset on all meters.

The full Modbus protocol consists of many commands and modes of operation to suit a variety of controllers and applications. The Power Rail Options Module utilises only a few commands and a single transmission mode to perform many functions specific to metering.

5.8.2 RTU. Transmission Mode

The RTU (Remote Terminal Unit) mode is utilised by the Power Rail Options Module because it provides the most efficient throughput of data at any particular baud rate.

In RTU mode, the start and end of each message is marked by a silent period of at least 3.5 character periods (Approx. 3.5ms @ 9600 baud). This is shown in the RTU message frame in Figure 5.8 below.

START	ADDRESS	FUNCTION	DATA	CRC	END
SILENT PERIOD	8 BITS	8 BITS	n x 8 BITS	16 BITS	SILENT PERIOD

Figure 5.8 RTU Framing

The host (PC) initiates all transactions. Slave meters continuously monitor the network, looking for messages framed by silent periods. The first character detected, after a silent period, is assumed to be an address byte and is compared to the meters internal address (zero for broadcasts). An addressed slave reads the remainder of the message and acts upon it as required.

A slave tests the message to determine it's validity and uses the transmitted checksum (CRC) to detect communication errors. A slave will only reply to valid messages, received without error, specifically addressed to itself.

ADDRESS

Valid Modbus addresses are in the range 0-247. Individual meters may be assigned addresses in the range 1-247. Address 0 is retained for broadcast commands which are handled by all slaves. When a slave responds to a command it places its own address in the reply message.

Options Module

FUNCTION

The function code is a single byte telling the meter what type of operation to perform. Valid Modbus codes are in the range 1-255 decimal but the Power Rail Options Module handles only a small subset of these as summarised below.

Function code	Operation	Broadcast
03	Read Multiple Registers	No
04	Read Multiple Registers	No
06	Preset A Single Register	Yes
08	Loop Back Diagnostic	No
16	Preset Multiple Registers	Yes

Figure 5.9 Function Code Summary

DATA FIELD

Data from the host contains additional information for the meter specific to the command. For example the data field may specify which meter readings are required or new values for energy registers.

Data from a slave may contain meter readings or other information requested by the host. Slaves also use the data field to send error codes (**exceptions**).

The size of the data field varies depending on command type and usage. The data format may also vary from one command to another to suit the application. Instantaneous readings for example are transmitted as 2-byte Integers, whereas energy readings are formatted as 4-byte Long Integers. Data is always transmitted with the most significant byte first. Data formatting is described in more detail in the following sections.

CRC ERROR CHECKING

A 16 bit CRC (*Cyclic Redundancy Check*) field is tagged on to the end of all messages. This field is the result of a CRC calculation performed on the message contents. The CRC field is used by the host and receiving devices alike to determine the validity of the entire message string. A receiving device recalculates the CRC and compares it to the value contained in the message. A slave device ignores a message if the two values do not match.

Note

Use of the CRC is essential when communicating in noisy environments to reduce the effects of erroneous bit errors. The meter will not reply to commands with a CRC in error and the host should re-transmit the command after a pre-determined time-out period. If the host receives a string with a CRC in error the transaction should be re-initiated.

The CRC is calculated on all bytes of a message from the address to the last data byte inclusively. Each bit of the message is processed through the CRC calculation starting with the first bit of the address. The Modbus standard method of CRC calculation requires reversal of the data bytes as they are fed serially through the bit processing routines. A simpler method involves swapping the low and high order bytes of the CRC integer at the end of the calculation. This is shown in the following routine.

Options Module

The calculation is performed as follows :

1. Load a 16 Bit register (“CRC Register”) with FFFF Hex. (All 1’s).
2. Exclusive-OR the first 8 Bits of the message with the low-order byte of the CRC register. Put the result in the CRC register.
3. Shift the CRC register one bit to the right (divide by 2), filling the MSB with a zero.
4. If the bit shifted out in 3 is a 1, Exclusive-OR the CRC register with the value A001 Hex.
5. Repeat steps 3 and 4 until 8 shifts have been performed and the bits tested. A single byte has thus been processed.
6. Repeat steps 2 to 5 using the next 8 bit byte of the message until all bytes have been processed.
7. The final contents of the CRC register is tagged on to the end of the message with the most significant byte first.
8. Swap the low and high order bytes of the integer result

An implementation of the CRC calculation in C code is shown below :

```
unsigned int check_sum(unsigned char *buff, char start, char bytes)
{
    char byte_cnt, bit_cnt;          /* loop counters */
    unsigned int crc_reg;           /* Result register */
    unsigned int CRCHI, CRCLo; /*Low and high order bytes of the crc*/

    crc_reg = 0xFFFF;              /* Set the CRC register to all 1's */

    /* Repeat for each byte of sub string */
    for(byte_cnt=start; byte_cnt<(bytes+start); byte_cnt++)
    {
        crc_reg = crc_reg ^ (unsigned int)buff[byte_cnt]; /*EXOR CRC & Next Byte*/

        /* Test each bit of the CRC */
        for(bit_cnt=0; bit_cnt<8; bit_cnt++)
        {
            if(crc_reg & 0x0001)
            {
                crc_reg = crc_reg >> 1; /* IF LSB=1 EXOR CRC with A001H */
                crc_reg = crc_reg ^ 0xA001; /* Then shift CRC toward LSB */
            }
            else crc_reg = crc_reg >> 1; /* ELSE Shift CRC towards LSB */
        }
    }
    CRCLo=crc_reg>>8; /*Swap the low and high order bytes of the crc result*/
    CRCHI=crc_reg<<8;
    crc_reg = CRCLo+CRCHI;
    return crc_reg;                /* Final CRC register Result */
}
```

Options Module

5.8.3 Power Rail Data Tables

Data in the Power Rail Options Module is arranged in several tables for convenience. Individual tables contain like information. Table data may be read only (eg. Instantaneous readings) or read/write access (eg. CT primary).

Data in each table is addressed in a Modbus command by two consecutive bytes. The first byte defines the table number and the second byte the offset of the data in the table. For example, 'address 2 , 1' would access Table 2, Entry 1 (3-Phase kWh). The Modbus standard defines data addresses using an integer. In the case of the Power Rail Options Module the high byte of this integer is represented by the table number and the low byte by the offset. A Modbus integer address may be calculated as :

$$\text{Modbus Data Address} = (256 \times \text{Table No}) + \text{Table Offset}$$

The format of data in a table is defined to suit the type of information it holds. Table 2 for example uses Long Integers to hold energy readings.

INTEGERS (Int)

Integers are 16 bit values transmitted as two 8 bit bytes. The most significant byte is always transmitted first. These values vary in the range -32767 to +32767 although some registers have a limited range of acceptable values. The most significant bit defines the sign, zero indicating positive.

LONG INTEGERS (Long Int)

Long Integers are 32 bit values transmitted as four 8-bit bytes. The most significant byte is always transmitted first.

Table 1 Instantaneous Meter Readings

Offset	Addr	Contents	Format	Bytes	Words	Access	Limits
0	256	±kW	Integer	2	1	R	±19,999
1	257	kW dp	Integer	2	1	R	0-6
2	258	Ave kW	Integer	2	1	R	±19,999

±kW Instantaneous kW as displayed on the Power Rail with no dp.

kW dp Decimal Scaling of kW and Rolling Average kW as

kW dp	Power Rail Display Range
0	0.00 - 199.99 W
1	0.0 - 1999.9 W
2	0.000 - 19.999 kW
3	0.00 - 199.99 kW
4	0.0 - 1999.9 kW
5	0.000 - 19.999 MW
6	0.00 - 199.99 MW

Ave kW Rolling Ave kW as displayed on the Power Rail with no dp.

Options Module

Table 2 Energy Registers

Offset	Addr	Contents	Format	Bytes	Words	Access	Limits
0	512	kWh dp	Long	4	2	R	0-6
1	513	Rail kWh	Long	4	2	R/W	9,999,999
2	514	Peak kW	Long	4	2	R/W	9,999,999
3	515	Scratch 1	Long	4	2	R/W	4,294,967,295
4	516	Scratch 2	Long	4	2	R/W	4,294,967,295

kWh dp Decimal Scaling of Rail kWh as

kWh dp	Power Rail Display Range
0	0.0 - 999999.9 Wh
1	0 - 9999999 Wh
2	0.00 - 99999.99 kWh
3	0.0 - 999999.9 kWh
4	0 - 9999999 kWh
5	0.00 - 99999.99 MWh
6	0.0 - 999999.9 MWh

- Rail kWh** Energy Reading as displayed on Power Rail with no dp.
- Peak kW** Peak Rolling Demand as displayed on Power Rail with no dp.
- Scratch 1** User scratch variable. Has no effect on meter/options unit.
- Scratch 2** User scratch variable. Has no effect on meter/options unit.

Note : The Scratch variables are destroyed on power failure of the options unit.

Table 3 Meter Setup

Offset	Addr	Contents	Format	Bytes	Words	Access	Limits
0	768	CT Pri / 10	Integer	2	1	R/W	1-200
1	769	Scale 10 ⁿ	Integer	2	1	R/W	0-3
2	770	Nom V	Integer	2	1	R	1-5
3	771	MD Period	Integer	2	1	R/W	1-60 (mins)
4	772	Pls Rate	Integer	2	1	R/W	0-3
5	773	Pls T / 10	Integer	2	1	R/W	1-255

CT Pri /10	CT Primary Current setting (1-200 => 10A - 2000A)
Scale 10ⁿ	Scaling Factor setting (0=>0.1, 1=>1.0, 2=>10.0, 3=>100.0)
Nom V	Hardware Nominal V _{LN} (1=60V, 2=120V, 4=240V, 5=300V)
MD Period	Rolling Average Demand Period in minutes
Pls Rate	Pulse Rate (10 ⁿ Counts Of Register Per Pulse Output. n=0-3)
Pls T / 10	Output Pulse On Time /10 (1-255 => 100ms - 25.5 sec)

Options Module

Table 7 Meter Description

Offset	Addr	Contents	Format	Bytes	Words	Access	Limits
0	1792	Mtr Type	Integer	2	1	R	514
1	1793	Serial No	Integer	2	1	R	1-65,535
2	1794	S/W Ver	Integer	2	1	R	11H - 99H

Mtr Type Code 514 Identifies the Power Rail standard meter.
Serial No Unique Serial Number for the Options Module
S/W Ver Software Release Version of the Options Module
eg 35H = Version 3.05

Table 8 Comms Setup

Offset	Addr	Contents	Format	Bytes	Words	Access	Limits
0	2048	Access	Integer	2	1	R/W	0-255
1	2049	Addr	Integer	2	1	R/W	1-247
2	2050	Baud Rate	Integer	2	1	R/W	48, 96, 192

Access 123 is required before Addr and/or Baud may be written
Addr Modbus Address for the Options Module
Baud Rate Modbus Baud Rate/100 for the Options Module

5.8.4 RTU Commands**5.8.5 Function 04 (or 03) Read Multiple Registers****Description**

This function allows a number of registers from a meter table to be read in a single operation. This command is commonly used to obtain instantaneous, energy or setup data from the meter. This command is not available as a *broadcast* command as it requires a return data packet from the meter.

Host Request

	BYTE	EXAMPLE
METER ADDRESS	1	19 H
FUNCTION	2	04 H
TABLE NUMBER (Address High Byte)	3	01 H
TABLE OFFSET (Address Low Byte)	4	00 H
No. OF WORDS (N) (High Byte)	5	00 H
No. OF WORDS (N) (Low Byte)	6	03 H
CHECKSUM (High Byte)	7	B2 H
CHECKSUM (Low Byte)	8	2F H

Options Module

Meter Response

	BYTE	EXAMPLE
METER ADDRESS	1	19 H
FUNCTION	2	04 H
NUMBER OF BYTES (2N)	3	06 H
DATA REGISTER 1 (High Byte)	4	kW MSB
DATA REGISTER 1 (Low Byte)	5	kW LSB
DATA REGISTER 2 (High Byte)	6	kW dp MSB
DATA REGISTER 2 (Low Byte)	7	kW dp LSB
DATA REGISTER N (High Byte)	8	Ave kW MSB
DATA REGISTER N (Low Byte)	9	Ave kW LSB
CHECKSUM (High Byte)	10	CRC MSB ❶
CHECKSUM (Low Byte)	11	CRC LSB ❶

The example shows a host request for data from Table 1 Instantaneous Meter Readings. The data requested starts at kW (Offset=0) and is for 3 Words. The meter returns kW, kW dp and Ave kW as integers. The meter therefore returns a Byte Count of 6.

❶ The checksum received from the meter is dependant on the data transmitted.

5.8.6 Function 06 Preset a Single Register**Description**

This function allows a single integer register in a meter table to be changed by the host. This command is commonly used to program meter parameters or to reset energy registers to zero. When broadcast (address=0) all meters on the network are addressed together but none reply.

Host Request

	BYTE	EXAMPLE
METER ADDRESS	1	19 H
FUNCTION	2	06 H
TABLE NUMBER (Address High Byte)	3	02 H
TABLE OFFSET (Address Low Byte)	4	01 H
DATA VALUE (High Byte)	5	C3 H
DATA VALUE (Low Byte)	6	50 H
CHECKSUM (High Byte)	7	8A H
CHECKSUM (Low Byte)	8	A6 H

Options Module

Meter Response

	BYTE	EXAMPLE
METER ADDRESS	1	19 H
FUNCTION	2	06 H
TABLE NUMBER (Address High Byte)	3	02 H
TABLE OFFSET (Address Low Byte)	4	01 H
DATA VALUE (High Byte)	5	C3 H
DATA VALUE (Low Byte)	6	50 H
CHECKSUM (High Byte)	7	8A H
CHECKSUM (Low Byte)	8	A6 H

The example shows a host request to set the kWh energy register (Table 2, Offset 1) to 50,000 (C3 50 Hex). The meter responds with a repeat of the host message after the register has been successfully written.

NOTE : This Modbus command is limited to writing 2-byte data only. Long Integer registers may be written as in the example above where the upper bytes are automatically set to zero by the meter.

5.8.7 Function 08 Loop Back Diagnostic**Description**

This function provides a simple means of testing the communication network and detecting if a particular meter is present.. This command is not available as a *broadcast* command as it requires a return data packet from the meter.

Host Request

	BYTE	EXAMPLE
METER ADDRESS	1	19 H
FUNCTION	2	08 H
DIAGNOSTIC CODE (High Byte)	3	00 H
DIAGNOSTIC CODE (Low Byte)	4	00 H
DIAGNOSTIC DATA (High Byte)	5	03 H
DIAGNOSTIC DATA (Low Byte)	6	E8 H
CHECKSUM (High Byte)	7	E3 H
CHECKSUM (Low Byte)	8	6D H

Options Module

Meter Response

	BYTE	EXAMPLE
METER ADDRESS	1	19 H
FUNCTION	2	08 H
DIAGNOSTIC CODE (High Byte)	3	00 H
DIAGNOSTIC CODE (Low Byte)	4	00 H
DIAGNOSTIC DATA (High Byte)	5	03 H
DIAGNOSTIC DATA (Low Byte)	6	E8 H
CHECKSUM (High Byte)	7	E3 H
CHECKSUM (Low Byte)	8	6D H

The example shows a loop back diagnostic with the test data set to 1000 (03 E8 Hex). The data byte is arbitrary.

NOTE : Modbus defines a number of diagnostic commands, each identified by a different code. The Power Rail Options Unit only supports Code=0 which returns the host command string as sent.

5.8.8 Function 16 Preset Multiple Registers

Description

This function allows a number of registers in a meter table to be set, by the host, in a single operation. This command is commonly used for setting energy registers or changing programmable setup parameters. When broadcast (address=0) all meters on the network are addressed together but none reply.

Host Request

	BYTE	EXAMPLE
METER ADDRESS	1	19 H
FUNCTION	2	10 H
TABLE NUMBER (Address High Byte)	3	03 H
TABLE OFFSET (Address Low Byte)	4	00 H
NUMBER OF DATA WORDS (N) (High Byte)	5	00 H
NUMBER OF DATA WORDS (N) (Low Byte)	6	03 H
NUMBER OF DATA BYTES (2N)	7	06 H
DATA BYTE 1	8	Meter K
DATA BYTE 2	9	Scale 10 ⁿ
DATA BYTE 3	10	Nom V
DATA BYTE 4	11	MD Period
DATA BYTE 5	12	Pls Rate
DATA BYTE 6	13	Pls T / 10
CHECKSUM (High Byte)	14	CRC MSB
CHECKSUM (Low Byte)	15	CRC LSB

Options Module

Meter Response

	BYTE	EXAMPLE
METER ADDRESS	1	19 H
FUNCTION	2	10 H
TABLE NUMBER (Address High Byte)	3	03 H
TABLE OFFSET (Address Low Byte)	4	00 H
NUMBER OF DATA WORDS (High Byte)	5	00 H
NUMBER OF DATA WORDS (Low Byte)	6	03 H
CHECKSUM (High Byte)	7	83 H
CHECKSUM (Low Byte)	8	94 H

Command 16 may be used to preset Integers (words) and Long integers equally. Long Integers are transmitted High byte first with the number of DATA WORDS (N) set to 2 x the number of registers.

The type of data sent is dependant on the Table selected. (eg Long Integer Data must be sent to preset values in Table 2).

5.8.9 Exception Responses

When a host sends a query to an individual meter on the network it expects a normal response. In fact one of four possible events may occur as a result of the query :

- ◇ If the meter receives the message with no communication errors, and can handle the query it will reply with a normal response.
- ◇ If the meter does not receive the message due to a communication failure, no response will be returned and the host will eventually time-out.
- ◇ If the meter receives the message but detects a communication error via its CRC, no response will be returned and the host will eventually time-out.
- ◇ If the meter receives the query with no communication errors but cannot handle the query (out of range data or address) the response will be an **Exception Response** informing the host of the nature of the error.

An Exception Response differs from a normal response in its Function Code and Data Fields.

Exception Response

	BYTE	EXAMPLE
METER ADDRESS	1	19 H
FUNCTION	2	84 H
EXCEPTION CODE	3	02 H
CHECKSUM (High Byte)	4	42 H
CHECKSUM (Low Byte)	5	C6H

Options Module

EXCEPTION FUNCTION CODE

All normal function types have a most significant bit of 0 (< 80 Hex). In an Exception Response the meter sets the MSB to 1 (adds 80H to the received Function Type). The Function can therefore be used by the host to detect an Exception Response.

DATA FIELD

In an Exception Response the data field is used only to return the type of error that occurred (***Exception Code***).

The Power Rail Options Unit Utilises the following Exception Codes :

Code	Meaning
1	Function Code Not Recognised
2	Table and/or offset out of range for this function
3	Data value too big
4	Data value too small
5	Data value not valid (eg comms baud must be 48,96 or 192)
6	Comms Access code not set (baud and/or address data unchanged)

5.9 Modbus Diagnostics LEDs

The Power Rail Options unit uses 4 LEDs to aid commissioning into a Modbus system. These indicators are also useful to check continued operation of the device.

The LEDs are intelligent indicators which are illuminated under specific conditions as follows :

- | | |
|-------------------------------|---|
| <i>POWER RAIL OK</i> | Illuminated when the auxiliary supply to the options unit is applied. Flashes when communicating with Power Rail. |
| <i>VALID COMMAND</i> | Illuminated when a host command is received, surrounded by RTU frame breaks (ref 5.8.4) with the correct Modbus address. |
| <i>ERROR/EXCEPTION</i> | Illuminated when a Valid Command is received as above but a CRC Error (ref 5.8.2) or Exception Condition (ref 5.8.9) is detected. |
| <i>BUS ACTIVITY</i> | Illuminated whenever changes occur on the receive input pins of the module. |

Specification

6. Specification

6.1 Power Rail

Inputs	
System	3-Phase 3 or 4 Wire Unbalanced Load 3-Phase Balanced and Single Phase to order
Voltage	230 / 400 Volt. 3-Phase 3 or 4 Wire 63 / 110 Volt optional 120 / 208 Volt optional
Current	5 Amp from external current transformers (CTs) 1 Amp optional Fully Isolated
Measurement Range Voltage Current	 50% to 120% 0.5% to 120%
Frequency Range Fundamental Harmonics	 45 to 65Hz Up to 50th harmonic
Input Loading Voltage Current	 Less than 0.1 VA per phase Less than 0.1 VA per phase
Overloads Voltage Current	 x2 for 2 seconds maximum x20 for 0.5 seconds maximum

Auxiliary Supply	
Standard	230 Volt 50/60Hz $\pm 15\%$
Options	110 Volt 50/60Hz $\pm 15\%$. Others to order
Load	3 VA Maximum

Display	
Display Type	Custom, supertwist, LCD with LED backlight
Data Retention	10 years minimum Stores kWh, Peak Demand, User Settings.
Display Format kW & kW Demand kWh Display Pages Scaling Legends Display Update	2 Lines of 7 9mm high digits + 4mm custom legends 4½ digits maximum. DP dependant on user settings 7 digits. DP dependant on user settings kW/kWh, kW Demand/Peak Demand and setup. Direct reading. User programmable CT, VT W, kW, MW etc dependant on user settings kW/kWh 1 sec. Rolling/Peak Demand T/15 T=Demand Period
Demand Period Setting Resolution	User programmable 1 to 60 minutes Demand period split into 15 sub periods

Accuracy	
kW	Better than 0.2% of Full Scale
kWh	Better than Class 1 per EN 61036 (IEC 1036)
kW Demand	Better than 0.2% of Full Scale
Peak Demand	Better than 0.2% of Full Scale
Timebase	Better than 100ppm

Specification

Output Relay	
Function	1 pulse per unit of energy
Scaling	Settable 1,10,100 or 1000 counts of kWh register
Pulse Period	Settable 0.1 - 25.5 seconds (0.1s steps) On time 2.0ms, Off time 2.0mS
Type	N/O Volt free contact. Optically isolated BiFET
Contacts	100mA AC/DC max, 100V AC/DC max
Isolation	2.5kV

General	
Temperature Operating Storage	-10 deg C to +65 Deg C -25 deg C to +70 deg C
Humidity	<75% non-condensing
Environment	IP 20

Mechanical (Rail 323)	
Enclosure	DIN 42880, 6 Modules. NORYL ULV94-V-O
Dimensions	106mm x 90mm x 58mm (6 Modules wide)
Weight	Approx 400g
DIN Rail	DIN EN 50022 106mm (min) x 35mm
Terminals	Rising Cage. 4.0mm ² cable max

6.2 Options Module

Auxiliary Supply (Options Module)	
Standard	230 Volt 50/60Hz ±15%
Options	110 Volt 50/60Hz ±15%
Load	3 VA Maximum
Isolation	2.5 kV continuous

Local Comms (Options Module-Power Rail)	
Function	Power Rail sends measurements/setup each second Options Module replies with updated setup if required CRC checksums used for verification
Protocol	ND Power Rail Options Version 1.1
Indication	Power Rail OK LED if Checksums correct
Connection	5 Pin Plug on Options Module, Socket on Power Rail
Isolation	Optical Isolation in Options Module to 2.5kV

Mechanical (Options Module)	
Enclosure	DIN 42880, 4 Modules. NORYL ULV94-V-O
Dimensions	71mm x 90mm x 58mm (4 Modules wide)
Weight	Approx 300g
DIN Rail	DIN EN 50022 71mm (min) x 35mm
Terminals	Rising Cage. 2.5mm ² cable max

Specification

Analogue Outputs (Options Module)	
Type	Dual 4-20mA Current Output
Scaling Output A Output B	4-20mA Proportional to 0-FS kW 4-20mA Proportional to 0-FS Rolling Average kW
Update Rate Output A Output B	1 Second T/15 where T is the demand period
Over-Range	20%
Resolution Accuracy	10 bit represents 0-120% of measured value ±0.5 % Rdg (In addition to meter error)
Power Supply Loop Powered Internal Supply	15-30V dc. at the module terminals. 25mA per output 18V dc. nominal. 50mA max.
Isolation	2.5kV from Power Rail and Aux Mains of Options Unit

Serial Comms (Options Module)	
Bus Type RX Loading TX Drive	RS422 / RS485 4/2 Wires + 0V. Half Duplex 1/4 Unit Load Per Options Module 32 Unit Loads
Protocol	Modbus™ RTU with 16 bit CRC. (JBUS compatible)
Baud Rate	4800, 9600 or 19200 user programmable
Address	User Programmable 1-247
Speed Reply Time Max Data Packet Commands Rate Example	20ms maximum from command end to reply start Any Table (Energy, Instantaneous, setup etc) New command within 5ms of previous Instantaneous Readings taken from a minimum of 20 meters each second at 9600 baud

Northern Design (Electronics) Ltd,
228 Bolton Road, Bradford,
West Yorkshire, BD3 0QW, England.

Telephone: +44 (0) 1274 729533

Fax: +44 (0) 1274 721074

Email: sales@ndmeter.co.uk

Or: support@ndmeter.co.uk

Copyright © Northern Design 2000

Mmm – YY Q K P