

# **MultiCube Options**

## **Modbus Communications**

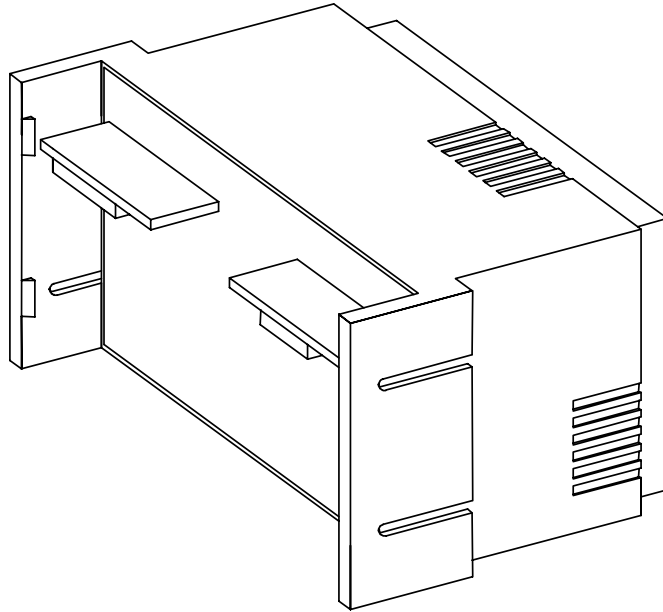

**Installation and Operation**

# PREFACE

<p><b>MultiCube Modbus Options Module Operating Guide Revision 1.01 MAY 2000</b></p>
--

This manual represents your options module as manufactured at the time of publication. It assumes standard software. Special versions of software may be fitted, in which case you will be provided with additional details.

Every effort has been made to ensure that the information in this manual is complete and accurate. We revised this manual but cannot be held responsible for errors or omissions.

The apparatus has been designed and tested in accordance with EN 61010-1, 'Safety Requirements for Electrical Equipment for Measurement, Control and Laboratory Use'. This operating guide contains information and warnings, which must be followed by the user to ensure safe operation and to maintain the apparatus in a safe condition.

We reserve the right to make changes and improvements to the product without obligation to incorporate these changes and improvements into units previously shipped.

General Editor : Ian Sykes BSc (hons).

Copyright © 2000 : Northern Design (Electronics) Ltd,  
228 Bolton Road, Bradford. West Yorkshire. UK.

## Table Of Contents

<b>1.</b>	<b>SAFETY</b> .....	<b>4</b>
1.1	WARNING SYMBOLS .....	4
1.2	MAINTENANCE .....	4
<b>2.</b>	<b>DESCRIPTION</b> .....	<b>5</b>
2.1	AVAILABLE PARAMETERS .....	6
<b>3.</b>	<b>CONNECTING THE OPTIONS UNIT</b> .....	<b>7</b>
<b>4.</b>	<b>OPERATION</b> .....	<b>8</b>
4.1	LOCAL COMMUNICATIONS (METER-OPTIONS MODULE).....	8
4.2	PROGRAMMING .....	9
4.2.1	Setting Baud Rate .....	9
4.2.2	Setting Meter Address .....	10
<b>5.</b>	<b>MODBUS COMMUNICATION</b> .....	<b>11</b>
5.1	DESCRIPTION.....	11
5.1.1	Communication Address.....	11
5.1.2	Data Format .....	11
5.2	RS485.....	12
5.2.1	RS485 Connection .....	13
5.3	RS422.....	14
5.3.1	RS422 Connection .....	15
5.4	MODBUS PROTOCOL.....	16
5.4.1	An Introduction To Modbus.....	16
5.4.2	RTU. Transmission Mode.....	17
5.4.3	CRC ERROR CHECKING .....	19
5.5	OPTIONS MODULE DATA TABLES .....	22
5.5.1	Table 2 Accumulated Energy Readings .....	23
5.5.2	Table 11 Instantaneous Meter Values.....	25
5.5.3	Table 12 Additional Instantaneous Values .....	26
5.5.4	Table 13 Peak Values.....	26
5.5.5	Table 14 Meter Set-up.....	28
5.5.6	Table 15 Peak Current and Voltage Demand.....	29
5.5.7	Table 16 Current and Voltage Demand.....	29
	RTU COMMANDS .....	30
5.5.8	Function 04 (or 03) Read Multiple Registers .....	30
5.5.9	Function 06 Preset a Single Register .....	32
5.5.10	Function 08 Loop Back Diagnostic.....	34
5.5.11	Function 16 Preset Multiple Registers.....	36
5.5.12	Exception Responses .....	38
5.6	MODBUS DIAGNOSTICS LEDs .....	40
<b>6.</b>	<b>SPECIFICATION</b> .....	<b>41</b>

## 1. Safety

### 1.1 Warning Symbols

This manual provides details of safe installation and operation of the options module. Safety may be impaired if the instructions are not followed. Labels on individual devices give details of equipment ratings for safe operation. Take time to examine all labels on the meter and to read this manual before commencing installation.



**Caution**  
**Refer to User Instructions**



**Danger**  
**Risk of Electric Shock**

Figure 1.1 Safety Symbols

**WARNING**

The equipment contains no user serviceable parts. Installation and commissioning should be carried out by qualified personnel

### 1.2 Maintenance

The equipment should be maintained in good working order. Damage to the product should be repaired by the manufacturer. The options module may be cleaned by wiping lightly with a soft cloth. No solvents or cleaning agents should be used. All inputs and supplies, to the meter and options module must be isolated before cleaning any part of the equipment.

## 2. Description

The Modbus Options Module adds multi-drop serial communications to any standard MultiCube meter. The device uses a high speed microprocessor to extract information from the meter and interface to an industry standard Modbus system.

Use of a dedicated communications processor ensures optimum efficiency, allowing fast access to data on systems with multiple meters. The use of Modbus protocol ensures compatibility with existing systems and/or a number of readily available software packages.

The Options Module may be configured as RS485 or RS422 providing 2 or 4 wire communications over distances up to 1200 metres. Data rates of 4800, 9600 or 19200 may be selected to suit system requirements.

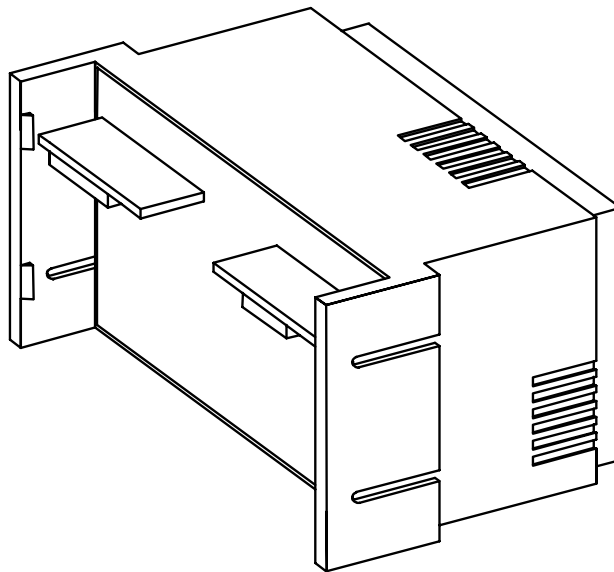

Figure 2.1 Options Module

## 2.1 Available Parameters

The Options Module is available in two forms.

The 'Standard' unit provides access to MultiCube measured parameters, which may be seen on the meters LCD display. Parameters not provided on a particular MultiCube meter type are set to zero in the Modbus tables (refer to section 5.5).

The 'All Value' unit provides access to all parameters shown in the tables in section 5.5.

Both types of Options Unit provide access to standard programmable meter settings such as CT primary.

## 3. Connecting The Options Unit

To connect the Options Module to the MultiCube:

1. Isolate **All** inputs/outputs to the MultiCube.
2. Check the ratings on the options module and meter to ensure compatibility.
3. Use a sharp knife to remove the cutout section from the rear of the MultiCube. Ensure the knife blade does not penetrate > 3mm.
4. Insert the Options Module into the slot on the rear of the meter.
5. Slide the Module fully home until all four mounting lugs 'click' into place as shown below.

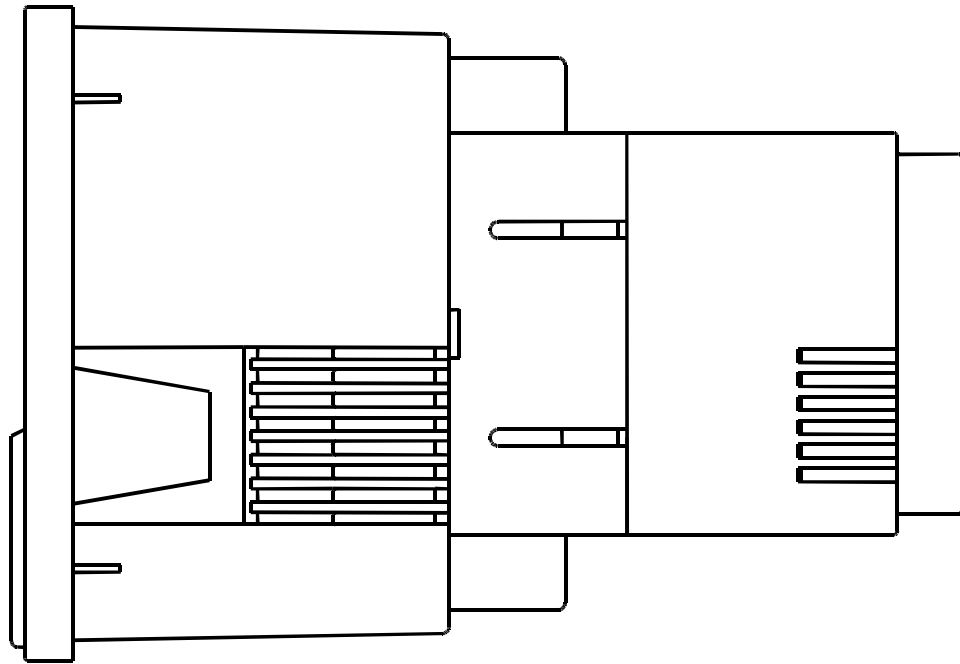

Figure 3.1 Options Module Attached to MultiCube

## 4. Operation

### 4.1 Local Communications (Meter-Options Module)

Once connected and powered up the MultiCube and Options Unit will begin communicating with each other automatically. All readings taken by the meter are sent to the Options Module each second along with all meter program settings. The Options Module replies with confirmation of the values and any requests to alter meter settings.

The MultiCube will confirm that it is correctly connected to an Options Module by illuminating the '**Options**' LED on its front panel. If for any reason the local communications fails this LED will switch off.

## 4.2 Programming

The MultiCube programming menu will automatically expand to include Baud Rate and Address settings when a valid Modbus Options Module is detected.

### 4.2.1 Setting Baud Rate

Remote serial communications speeds of 4800, 9600 or 19200 may be selected to suit external system requirements. Higher speeds will provide faster data access while a slower speed may be required in electrically noisy environments.

Enter programming mode on the MultiCube as described in the Meter Operating Instructions. Scroll through program settings using  $\downarrow$  until the meter displays 'Baud Rate'.

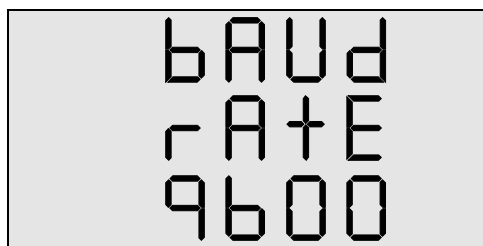

Figure 4.2 Setting The Baud Rate

Press  $\triangle$  to select the next highest available baud rate setting.

Press  $\nabla$  to select the next lowest available baud rate setting.

Press  $\leftarrow$  and hold for 2 seconds when done.

## 4.2.2 Setting Meter Address

Each outstation (Meter) on a multi-drop Modbus system is identified to the master by a unique address. The MultiCube may be addressed anywhere in the full Modbus range of 1-247.

Enter programming mode on the MultiCube as described in the Meter Operating Instructions. Scroll through program settings using  $\downarrow$  until the meter displays 'Cube Addr'.

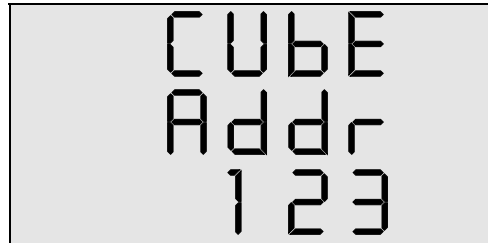

Figure 4.3 Setting The Modbus Address

Press  $\triangle$  to increment the Modbus Address.

Press  $\nabla$  to decrement the Modbus Address.

Press  $\downarrow$  and hold for 2 seconds when done.

## 5. Modbus Communication

### 5.1 Description

The MultiCube Options Module provides a serial communications interface to external systems. This allows remote reading and programming of the meter by a host computer (e.g. PC). The output may be wired as RS422 (full duplex) or RS485 (half duplex).

The communication protocol used is a subset of Modicon's Modbus enabling use of standard off the shelf software packages and connection to standard controllers.

#### 5.1.1 Communication Address

Each meter on a Modbus serial communication network must be assigned a unique address between 1 and 247. This is carried out in programming mode as described in Section 4.2. If two or more meters, connected in a multi-drop network have the same address, data on the network will be corrupted and communication will fail.

#### 5.1.2 Data Format

The device uses a fixed data format for serial communications:

1 Start Bit	8 Data Bits	1 Stop Bit
-------------	-------------	------------

The 8 data bits are always transmitted least significant bit first. This data byte is binary coded.

The baud rate is programmable as **4800, 9600, or 19200 baud**. This is carried out in programming mode as described in Section 4.2.

## 5.2 RS485

The RS485 communication option enables connection of up to 128 meters on a single pair of wires (247 with repeaters). The pair is used for transmission and reception with each meter (and the host) automatically switching data direction. The host should be fitted with an RS485 driver (or converter) capable of operation in two wire mode (half duplex).

PC operation in RS485 two-wire mode usually requires software control of the data direction. This controls the line drivers connected to the bus at the host serial port. This direction control requires high speed operation and may be problematic under certain operating systems such as Windows. It is advisable to check with the software vendor before selecting RS485 as the mode of operation.

If software data direction control is not suitable, RS232-RS485 converters are available for standard PCs, which carry out automatic hardware control. For more information on these contact your distributor.

Each Modbus serial transaction is preceded by a device address allowing the host to temporarily connect with any meter on the bus. Certain commands allow the host to transmit commands or data to all meters simultaneously.

These commands are known as **broadcasts** and use address 0. The RS485 standard enables reliable communication over a maximum distance of 1200 metres.

Standard line repeaters may be installed to increase the maximum distance of an RS485 network and/or the number of devices, which may be connected.

## 5.2.1 RS485 Connection

It is recommended that screened twisted-pair cable be used for RS485 connection in order to minimise signal errors due to noise. An optional third wire, connecting the common (0V) at each unit, is recommended for optimum performance. The cable screen should be connected to the connector housing (ground) at the host (PC) only. To reduce cable reflections over long distances, RS422/485 systems require line termination. This is achieved by fitting two  $120\Omega$  terminating resistors as shown in Figure 5.4. One resistor should be fitted at the Host input/output buffer and the other at the buffer of the most remote device.

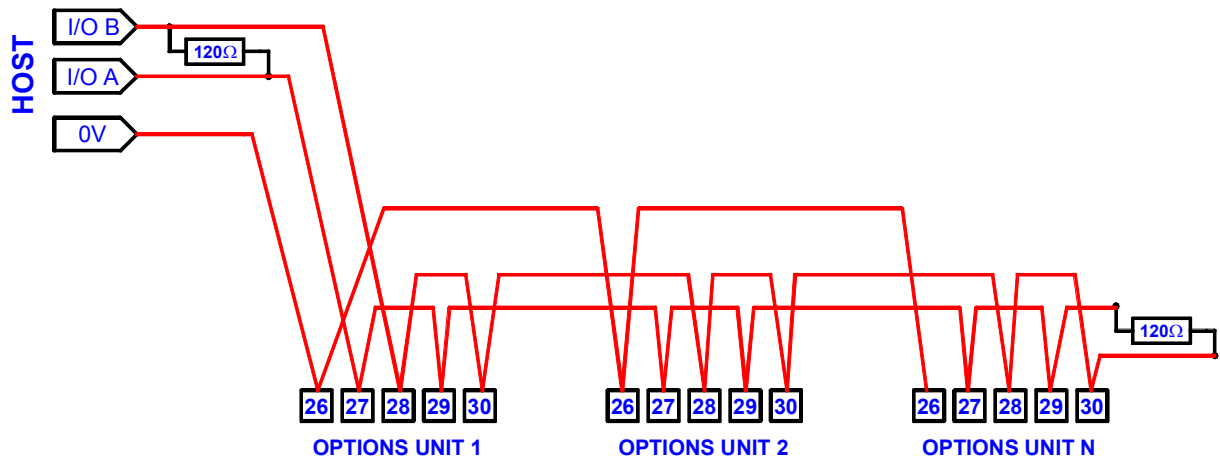

Figure 5.4 RS485 Multi-Drop Connection

## 5.3 RS422

The RS422 communication option enables connection of up to 128 meters (247 with repeaters) on two pairs of wires (4-wire bus). One pair is used for transmission and the other for reception.

This connection is more commonly used in full duplex communications systems where host and slave can simultaneously transmit/receive data. In this instance however, the Modbus protocol itself ensures half duplex operation by default. RS422 may be used in systems where the host is not capable of operation in RS485 mode with data direction control. The RS422 standard enables reliable communication over a maximum distance of 1200 metres. Standard line repeaters may be installed to increase the maximum distance of an RS422 network and/or the number of devices which may be connected.

## 5.3.1 RS422 Connection

It is recommended that screened 2 x twisted pair cable is used for RS422 connection in order to minimise signal errors due to noise. . An optional fifth wire, connecting the common (0V) at each unit, is recommended for optimum performance. The first pair should be used for RXA & RXB and the second for TXA & TXB. The screen should be connected to the connector housing (ground) at the host only. To reduce cable reflections over long distances, RS422 systems require line termination. This is achieved by fitting two 120Ω terminating resistors as shown in Figure 5.5. One resistor should be fitted at the Host receive input buffer and the other at the receive buffer of the most remote meter.

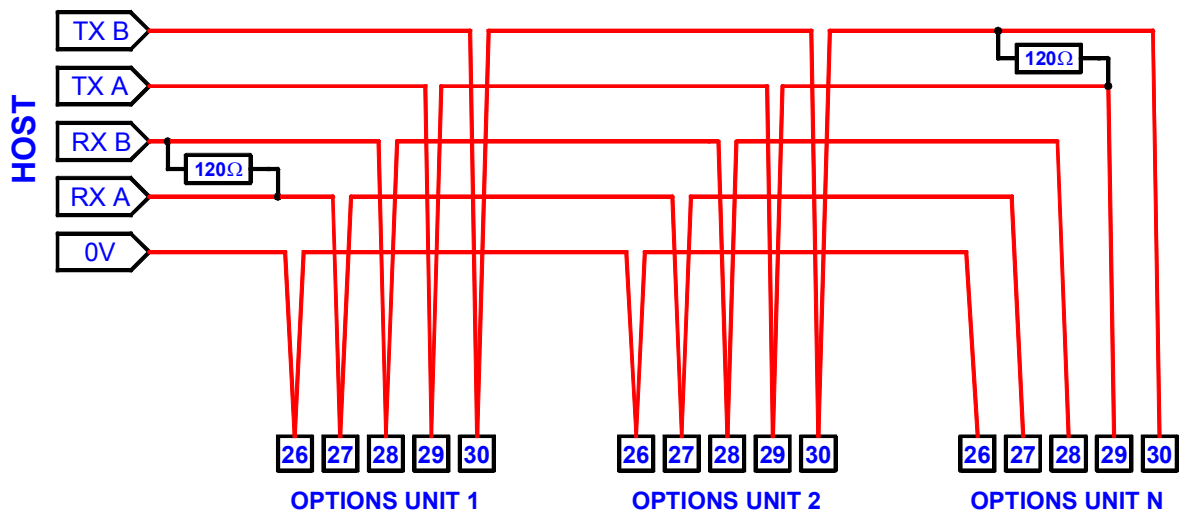

Figure 5.5 RS422 Multi-Drop Connection

## 5.4 Modbus Protocol

### 5.4.1 An Introduction To Modbus

A communication protocol defines a set of commands and data formats which will be recognised by all compatible equipment connected on a system. The protocol effectively forms a communication language.

The MultiCube Options Units utilise a subset of Modicon's 'Modbus' standard protocol. This protocol was originally developed for use by programmable logic controllers (PLCs). It defines a set of commands for reading and/or writing data to devices connected on the bus.

Modbus is a master-slave protocol with all transactions initiated by a single host (e.g. a PC). A single transaction commences with the host transmission of a command packet followed by a slave (Options Unit) reply after a short delay for processing the command.

Command packets consist of an address, a command identifier, data and a checksum for error detection. Each slave device continually monitors the bus looking for activity. Command packets are detected by all slaves but may be acted upon only by the device whose address matches that transmitted.

The host may transmit a ***broadcast command***, which uses address 0 to contact all devices on the network. In this instance all slaves act on the command but none of them may reply. This type of command may be useful, for example, in synchronising energy register reset on all meters.

The full Modbus protocol consists of many commands and modes of operation to suit a variety of controllers and applications. The MultiCube Options Module utilises only a few commands and a single transmission mode to perform many functions relevant to metering.

## 5.4.2 RTU. Transmission Mode

The RTU (Remote Terminal Unit) mode is utilised by the MultiCube Options Module because it provides the most efficient throughput of data at any particular baud rate.

In RTU mode, the start and end of each message is marked by a silent period of at least 3.5 character periods (Approx. 3.5ms @ 9600 baud). This is shown in the RTU message frame in Figure 5.6 below.

START	ADDRESS	FUNCTION	DATA	CRC	END
SILENT PERIOD	8 BITS	8 BITS	n x 8 BITS	16 BITS	SILENT PERIOD

Figure 5.6 RTU Framing

The host (PC) initiates all transactions. Slave devices continuously monitor the network, looking for messages framed by silent periods. The first character detected, after a silent period, is assumed to be an address byte and is compared to the meters internal address (zero for broadcasts). An addressed slave reads the remainder of the message and acts upon it as required. A slave tests the message to determine it's validity and uses the transmitted checksum (CRC) to detect communication errors. A slave will only act on valid messages, received without error, specifically addressed to it.

### ADDRESS

Valid Modbus addresses are in the range 0-247. Individual devices may be assigned addresses in the range 1-247. Address 0 is retained for broadcast commands which are handled by all slaves. When a slave responds to a command it places its own address in the reply message.

## FUNCTION

The function code is a single byte telling the device what type of operation to perform. Valid Modbus codes are in the range 1-255 decimal but the MultiCube Options Module handles only a small subset of these as summarised below.

Function code	Operation	Broadcast
03	Read Multiple Registers	No
04	Read Multiple Registers	No
06	Preset A Single Register	Yes
08	Loop Back Diagnostic	No
16	Preset Multiple Registers	Yes

Figure 5.7 Function Code Summary

## DATA FIELD

Data from the host contains additional information for the remote device specific to the command. For example the data field may specify which meter readings are required or new values for energy registers.

Data from a slave may contain meter readings or other information requested by the host.

The size of the data field varies depending on command type and usage. The data format may also vary from one command to another to suit the application. Instantaneous readings for example are transmitted as 2-byte Integers, whereas energy readings are formatted as 4-byte Long Integers. Data is always transmitted with the most significant byte first. Data formatting is described in more detail in the following sections.

## 5.4.3 CRC ERROR CHECKING

A 16 bit CRC (*Cyclic Redundancy Check*) field is tagged on to the end of all messages. This field is the result of a CRC calculation performed on the message contents. The CRC field is used by the host and receiving devices alike to determine the validity of the entire message string. A receiving device recalculates the CRC and compares it to the value contained in the message. A slave device ignores a message if the two values do not match.

### Note

Use of the CRC is essential when communicating in noisy environments to reduce the effects of erroneous bit errors. The meter will not reply to commands with a CRC in error and the host should re-transmit the command after a pre-determined time-out period. If the host receives a string with a CRC in error the transaction should be re-initiated.

The CRC is calculated on all bytes of a message from the address to the last data byte inclusively. Each bit of the message is processed through the CRC calculation starting with the first bit of the address. The Modbus standard method of CRC calculation requires reversal of the data bytes as they are fed serially through the bit processing routines. A simpler method involves swapping the low and high order bytes of the CRC integer at the end of the calculation. This is shown in the following routine.

The calculation is performed as follows:

1. Load a 16 Bit register (“CRC Register”) with FFFF Hex. (All 1’s).
2. Exclusive-OR the first 8 Bits of the message with the low-order byte of the CRC register. Put the result in the CRC register.
3. Shift the CRC register one bit to the right (divide by 2), filling the MSB with a zero.
4. If the bit shifted out in 3 is a 1, Exclusive-OR the CRC register with the value A001 Hex.
5. Repeat steps 3 and 4 until 8 shifts have been performed and the bits tested. A single byte has thus been processed.
6. Repeat steps 2 to 5 using the next 8 bit byte of the message until all bytes have been processed.
7. The final contents of the CRC register is tagged on to the end of the message with the most significant byte first.
8. Swap the low and high order bytes of the integer result

An implementation of the CRC calculation in C code is shown below :

```
unsigned int check_sum(unsigned char *buff, char start, char bytes)
{
    char byte_cnt, bit_cnt;          /* loop counters */
    unsigned int crc_reg;           /* Result register */
    unsigned int CRCHi, CRCLO;      /*Low and high order bytes of the crc*/

    crc_reg = 0xFFFF;              /* Set the CRC register to all 1's */

    /* Repeat for each byte of sub string */
    for(byte_cnt=start; byte_cnt<(bytes+start); byte_cnt++)
    {
        crc_reg = crc_reg ^ (unsigned int)buff[byte_cnt]; /*EXOR CRC & Next Byte*/

        /* Test each bit of the CRC */
        for(bit_cnt=0; bit_cnt<8; bit_cnt++)
        {
            if(crc_reg & 0x0001)
            {
                crc_reg = crc_reg >> 1; /* IF LSB=1 EXOR CRC with A001H */
                crc_reg = crc_reg ^ 0xA001; /* Then shift CRC toward LSB */
            }
            else crc_reg = crc_reg >> 1; /* ELSE Shift CRC towards LSB */
        }
    }
    CRCLO=crc_reg>>8; /*Swap the low and high order bytes of the crc result*/
    CRCHi=crc_reg<<8;
    crc_reg = CRCLO+CRCHi;
    return crc_reg;                /* Final CRC register Result */
}
```

## 5.5 Options Module Data Tables

Data in the MultiCube Options Module is arranged in several tables for convenience. Individual tables contain like information. Table data may be read only (e.g. instantaneous readings) or read/write access (e.g. CT primary). Data in each table is pointed to in a Modbus command by two consecutive data address bytes. The first byte defines the table number and the second byte the offset of the data in the table. For example, 'address 2 , 1' would access Table 2, Entry 1 (3-Phase kWh ). The Modbus standard defines data addresses using a 16-bit integer. In the case of the MultiCube Options Module the high byte of this integer is represents the table number and the low byte the offset. A Modbus integer address may be calculated as:

$$\text{Modbus Data Address} = (256 \times \text{Table No}) + \text{Table Offset}$$

### **SIGNED INTEGER**

Signed Integers are 16 bit values transmitted as two 8 bit bytes. The most significant byte is always transmitted first. These values vary in the range -32767 to +32767 although some registers have a limited range of acceptable values. The most significant bit defines the sign, zero indicating positives.

### **UNSIGNED INTEGER**

Unsigned Integers are 16 bit values transmitted as two 8 bit bytes. The most significant byte is always transmitted first. These values vary in the range 0 to 65535 although some registers have a limited range of acceptable values.

### **UNSIGNED LONG INTEGERS (Unsigned Long)**

Unsigned long integers are 32 bit values transmitted as four 8-bit bytes. The most significant byte is always transmitted first. These values vary in the range 0 to 4294967295 although energy registers in the MultiCube have a limited range, 0-999999.

## 5.5.1 Table 2 Accumulated Energy Readings

Offset	Address	Contents	Format	Bytes	Words	Access
0	512	Energy Scale Hi	Unsigned Long	4	2	Read Only
1	513	Energy Scale Lo				
2	514	kWh Hi	Unsigned Long	4	2	Read/Write
3	515	kWh Lo				
4	516	kVAh Hi	Unsigned Long	4	2	Read/Write
5	517	kVAh Lo				
6	518	kvarh (Ind) Hi	Unsigned Long	4	2	Read/Write
7	519	kvarh (Ind) Lo				
8	520	kvarh (Cap) Hi	Unsigned Long	4	2	Read/Write
9	521	kvarh (Cap) Lo				

### 5.5.1.1 Energy Registers

Energy registers available for display on a MultiCube are stored in Modbus Table 2 as unsigned long integers. Registers not available on an individual meter are returned as zero.

### 5.5.1.2 Writing to Energy Registers

Function 6 or 16 may be used to write to the energy registers in Table 2. Function 6 allows access to the upper and lower integers of the 4-byte long individually. Upper integers have a maximum write value of 0x0F preventing out of range data being sent to the MultiCube. Function 16 may be used to access a number of long integers using a single command. This is most useful for setting all registers to 0 simultaneously. Valid commands must send an even number of integers (2 integers per long) starting at an even address in Table 2 (Start of a register). Failure to follow these basic rules will result in an exception response (ref. Section 5.5.12).

## 5.5.1.3 Energy Scaling

Energy readings from the MultiCube are stored as unsigned long integer values with no decimal point or legend (e.g. kWh or MWh). A single scaling factor is provided to enable conversion of the raw data to real numbers in basic unit form (Wh, VAh or varh). The scaling factor is a constant value calculated in the MultiCube as a function of CT and PT Primary programming. To convert raw data to real numbers:

$$E = L \times 10^{(K-3)}$$

**Where:**

- L** = Long Integer number
- K** = Energy Scaling Factor
- E** = Scaled Energy Result

### Example:

If the meter is programmed with CT Primary=50Amps and PT Primary=415V:  
The meter displays would be 99999.9 kWh, 99999.9 kVAh and 99999.9 kvarh  
The Energy Scaling Factor would be transmitted as: K=5  
Energy Registers would be transmitted as: 999999  
Wh would be calculated as  $999999 \times 10^{(5-3)} = 999999 \times 100 = 99999900\text{Wh}$   
VAh would be calculated as  $999999 \times 10^{(5-3)} = 999999 \times 100 = 99999900\text{VAh}$   
varh would be calculated as  $999999 \times 10^{(5-3)} = 999999 \times 100 = 99999900\text{varh}$

## 5.5.2 Table 11 Instantaneous Meter Values

Offset	Address	Contents	Format	Bytes	Words	Access
0	2816	kW 3-Ph	Signed Integer	2	1	Read Only <sup>4</sup>
1	2817	kVA 3-Ph	Signed Integer	2	1	Read Only <sup>4</sup>
2	2818	kvar 3-Ph	Signed Integer	2	1	Read Only <sup>4</sup>
3	2819	PF 3-Ph	Signed Integer	2	1	Read Only
4	2820	Frequency	Signed Integer	2	1	Read Only
5	2821	Phase 1 Volts	Signed Integer	2	1	Read Only <sup>2</sup>
6	2822	Phase 1 Amps	Signed Integer	2	1	Read Only <sup>1</sup>
7	2823	Phase 1 kW	Signed Integer	2	1	Read Only <sup>4</sup>
8	2824	Phase 2 Volts	Signed Integer	2	1	Read Only <sup>2</sup>
9	2825	Phase 2 Amps	Signed Integer	2	1	Read Only <sup>1</sup>
10	2826	Phase 2 kW	Signed Integer	2	1	Read Only <sup>4</sup>
11	2827	Phase 3 Volts	Signed Integer	2	1	Read Only <sup>2</sup>
12	2828	Phase 3 Amps	Signed Integer	2	1	Read Only <sup>1</sup>
13	2829	Phase 3 kW	Signed Integer	2	1	Read Only <sup>4</sup>
14	2830	Phase 1 PF	Signed Integer	2	1	Read Only
15	2831	Phase 2 PF	Signed Integer	2	1	Read Only
16	2832	Phase 3 PF	Signed Integer	2	1	Read Only
17	2833	Ph1-Ph2 Volts	Signed Integer	2	1	Read Only <sup>3</sup>
18	2834	Ph2-Ph3 Volts	Signed Integer	2	1	Read Only <sup>3</sup>
19	2835	Ph3-Ph1 Volts	Signed Integer	2	1	Read Only <sup>3</sup>
20	2836	Neutral Current	Signed Integer	2	1	Read Only <sup>1</sup>
21	2837	Amps Scale	Signed Integer	2	1	Read Only
22	2838	Ph Volts Scale	Signed Integer	2	1	Read Only
23	2839	Ln Volts Scale	Signed Integer	2	1	Read Only
24	2840	Power Scale	Signed Integer	2	1	Read Only

- Notes:**
1. Use 'Amps Scale' at Address 2837 to convert to real Amps.
  2. Use 'Ph Volts Scale' at Address 2838 to convert to real Volts.
  3. Use 'Ln Volts Scale' at Address 2839 to convert to real Volts.
  4. Use 'Power Scale' at Address 2840 to convert to real W, VA or var.

## 5.5.3 Table 12 Additional Instantaneous Values

Offset	Address	Contents	Format	Bytes	Words	Access
0	3072	Phase 1 kVA	Signed Int	2	1	Read <sup>4</sup>
1	3073	Phase 2 kVA	Signed Int	2	1	Read <sup>4</sup>
2	3074	Phase 3 kVA	Signed Int	2	1	Read <sup>4</sup>
3	3075	Phase 1 kvar	Signed Int	2	1	Read <sup>4</sup>
4	3076	Phase 2 kvar	Signed Int	2	1	Read <sup>4</sup>
5	3077	Phase 3 kvar	Signed Int	2	1	Read <sup>4</sup>

**Notes:** 4. Use 'Power Scale' at Address 2840 to convert to real W, VA or var.

## 5.5.4 Table 13 Peak Values

Offset	Address	Contents	Format	Bytes	Words	Access
0	3328	PK Hold I1	Signed Int	2	1	Read/Write <sup>5</sup>
1	3329	PK Hold I2	Signed Int	2	1	Read/Write <sup>5</sup>
2	3330	PK Hold I3	Signed Int	2	1	Read/Write <sup>5</sup>
3	3331	PK Hold V1	Signed Int	2	1	Read/Write <sup>6</sup>
4	3332	PK Hold V2	Signed Int	2	1	Read/Write <sup>6</sup>
5	3333	PK Hold V3	Signed Int	2	1	Read/Write <sup>6</sup>
6	3334	Peak kW MD	Signed Int	2	1	Read/Write <sup>8,9</sup>
7	3335	MD Period	Signed Int	2	1	Read/Write <sup>8</sup>
8	3336	kW MD	Signed Int	2	1	Read Only <sup>9</sup>

**Notes:** 5. Use 'Amps Scale' at Addr 2837 to convert to real peak hold Amps.  
 6. Use 'Ph Volts Scale' at Addr 2838 to convert to real peak hold V.  
 8. Peak kW MD & MD Period may **NOT** be written using Command 16.  
 9. Peak kW MD & MD are scaled as 3-Phase kW/10

### 5.5.4.1 Instantaneous/Peak Values

Instantaneous and peak measurements available for display on a MultiCube are stored in Modbus Tables 11-13 as Signed integers. Parameters not available on an individual meter are returned as zero. Negative values are used for per phase/system kvar and PF readings to represent capacitive loads. All other values will be returned as positive integers.

### 5.5.4.2 Scaling Instantaneous/Peak Values

Instantaneous readings from the MultiCube are provided as signed integer values with no decimal point or legend (e.g. kW or MW). Scaling factors are provided to enable conversion of the raw data to real numbers in basic unit form (amps, volts, watts, VA, or var). These scaling factors are constant values calculated in the MultiCube as a function of CT and PT Primary programming. To convert raw data to real numbers:

$$R = I \times 10^{(K-3)}$$

**Where:**

- I** = Integer number
- K** = Relevant Scaling Factor
- R** = Real number result

#### Example:

If the meter is programmed with CT Primary=50Amps and PT Primary=415V:  
The meter displays would be scaled as: 50.00A, 240.0V, 415.7V<sub>LL</sub>, 36.00kW  
Scaling factors would be as: I Scale=1, Vph Scale=2, VLL Scale=2, P Scale=4  
Integer Values would be transmitted as: 5000, 2400, 4157 and 3600  
Amps would be calculated as  $5000 \times 10^{(1-3)} = 5000/100 = 50.00A$   
Phase Volts would be calculated as  $2400 \times 10^{(2-3)} = 2400/10 = 240.0V$   
Line Volts would be calculated as  $4157 \times 10^{(2-3)} = 4157/10 = 415.7V$   
3-Ph Power would be calculated as  $3600 \times 10^{(4-3)} = 3600 \times 10 = 36000W$

Power factors are transmitted from the meter in the range -999 to 1000 representing measured values of 0.0 to 1.000. A negative value indicates a capacitive load.

Frequency is transmitted from the meter scaled by a factor of 10. For example a measured frequency of 50.0 would be transmitted as 500.

## 5.5.5 Table 14 Meter Set-up

Offset	Address	Contents	Format	Bytes	Words	Access
0	3584	CT Primary	unsigned Int	2	1	Read/Write <sup>10</sup>
1	3585	PT Primary	unsigned Int	2	1	Read/Write <sup>10</sup>
2	3586	Pulse 1 Rate	unsigned Int	2	1	Read/Write <sup>10</sup>
3	3587	Pulse 2 Rate	unsigned Int	2	1	Read/Write <sup>10</sup>
4	3588	Baud Rate	unsigned Int	2	1	Read/Write <sup>10</sup>
5	3589	Modbus ID	unsigned Int	2	1	Read/Write <sup>10</sup>
6	3590	Meter Model	unsigned Int	2	1	Read Only
7	3591	Meter Type	unsigned Int	2	1	Read Only
8	3592	Meter Software	unsigned Int	2	1	Read Only
9	3593	V/I MD Period	unsigned Int	2	1	Read/Write <sup>10</sup>

**Notes:** 10. Values in Table 14 may not be written using Command 16

### 5.5.5.1 Meter Set-up Values

Information about the MultiCube's configuration is available in Table 14 as unsigned integers.

- **CT Primary.** (5A - 6500A) CT Primary as displayed during meter set-up.
- **PT Primary.** (60V - 50000V) PT Primary as displayed during meter set-up.
- **Pulse 1 Rate.** (1 - 255) No. of counts of kWh register per pulse (if fitted).
- **Pulse 2 Rate.** (1 - 255) No. of counts of kvarh\* register per pulse (if fitted).
- **Baud Rate.** (48, 96 or 192) RS485/422 baud rates of 4800, 9600 or 19200.
- **Modbus ID** (1 – 247). Modbus Meter Address.
- **Meter Model** A constant identifying the product range (MultiCube=100).
- **Meter Type** (1 – 4). Refer to MultiCube manual for details of meter types.
- **Meter Software** MultiCube version (e.g. 0x0014 = Version 1.04).
- **V/I MD Period** (1-255) Time period (seconds/10) for Current and Voltage Demand. Eg. A value of 6 corresponds to a demand period of 60 seconds.

\* kVAh Pulsing may replace kvarh in some MultiCubes.

## 5.5.6 Table 15 Peak Current and Voltage Demand

Offset	Address	Contents	Format	Bytes	Words	Access
0	3840	Peak I1 MD	unsigned Int	2	1	Read/Write <sup>5</sup>
1	3841	Peak I2 MD	unsigned Int	2	1	Read/Write <sup>5</sup>
2	3842	Peak I3 MD	unsigned Int	2	1	Read/Write <sup>5</sup>
3	3843	Peak V1 MD	unsigned Int	2	1	Read/Write <sup>6</sup>
4	3844	Peak V2 MD	unsigned Int	2	1	Read/Write <sup>6</sup>
5	3845	Peak V3 MD	unsigned Int	2	1	Read/Write <sup>6</sup>

- Notes:**
5. Use 'Amps Scale' at Addr 2837 to convert to real Peak Amp Demand.
  6. Use 'Ph Volts Scale' at Addr 2838 to convert to real Peak Volts Demand.

The peak values of rolling demand averages of currents and voltages are available in Table 15 as unsigned integers.

## 5.5.7 Table 16 Current and Voltage Demand

Offset	Address	Contents	Format	Bytes	Words	Access
0	4096	I1 Demand	unsigned Int	2	1	Read Only <sup>5</sup>
1	4097	I2 Demand	unsigned Int	2	1	Read Only <sup>5</sup>
2	4098	I3 Demand	unsigned Int	2	1	Read Only <sup>5</sup>
3	4099	V1 Demand	unsigned Int	2	1	Read Only <sup>6</sup>
4	4100	V2 Demand	unsigned Int	2	1	Read Only <sup>6</sup>
5	4101	V3 Demand	unsigned Int	2	1	Read Only <sup>6</sup>

- Notes:**
5. Use 'Amps Scale' at Addr 2837 to convert to real Amp Demand.
  6. Use 'Ph Volts Scale' at Addr 2838 to convert to real Volts Demand.

The rolling demand averages of currents and voltages are available in Table 16 as unsigned integers.

**Note:** Tables 15 and 16 are only available in MultiCube meters with software versions 1.04 or later. An invalid table exception will be returned on earlier meters.

## RTU Commands

### 5.5.8 Function 04 (or 03) Read Multiple Registers

#### Description

This function allows a number of registers from a meter table to be read in a single operation. This command is commonly used to obtain instantaneous, energy or set-up data from the meter. This command is not available as a *broadcast* command as it requires a return data packet from the meter.

#### Host Request

	BYTE	EXAMPLE
METER ADDRESS	1	19H
FUNCTION	2	04H
TABLE NUMBER (Address High Byte)	3	0BH
TABLE OFFSET (Address Low Byte)	4	00H
No. OF WORDS (N) (High Byte)	5	00H
No. OF WORDS (N) (Low Byte)	6	03H
CHECKSUM (High Byte)	7	B1H
CHECKSUM (Low Byte)	8	F7H

The example above shows a read of 3 consecutive Integers from the Instantaneous Data Table 11(0BH), offset 0. The meter accessed has a Modbus ID of 25 (19H).

## Meter Response

	BYTE	EXAMPLE
METER ADDRESS	1	19H
FUNCTION	2	04H
NUMBER OF BYTES (2N)	3	06H
DATA REGISTER 1 (High Byte)	4	02H
DATA REGISTER 1 (Low Byte)	5	3AH
DATA REGISTER 2 (High Byte)	6	07H
DATA REGISTER 2 (Low Byte)	7	5CH
DATA REGISTER N (High Byte)	8	07H
DATA REGISTER N (Low Byte)	9	02H
CHECKSUM (High Byte)	10	51H
CHECKSUM (Low Byte)	11	E3H

The example shows a reply of 6 bytes (3 Integers) as:

3-Ph kW = 570 (02 3A Hex)

3-Ph kVA = 1884 (07 5C Hex)

3-Ph kvar = 1794 (07 02 Hex)

## 5.5.9 Function 06 Preset a Single Register

### Description

This function allows a single integer register in a meter table to be changed by the host. This command is commonly used to program meter parameters or to reset energy registers to zero. When broadcast (address=0) all meters on the network are addressed together but none reply.

### Host Request

	BYTE	EXAMPLE
METER ADDRESS	1	19 H
FUNCTION	2	06 H
TABLE NUMBER (Address High Byte)	3	0E H
TABLE OFFSET (Address Low Byte)	4	00 H
DATA VALUE (High Byte)	5	00 H
DATA VALUE (Low Byte)	6	C8 H
CHECKSUM (High Byte)	7	89 H
CHECKSUM (Low Byte)	8	6C H

The example above shows a value of 200 (00H C8H) written to the CT Primary register (Data Table 14, offset 0). The meter accessed has a Modbus ID of 25 (19H).

## Meter Response

	BYTE	EXAMPLE
METER ADDRESS	1	19 H
FUNCTION	2	06 H
TABLE NUMBER (Address High Byte)	3	0E H
TABLE OFFSET (Address Low Byte)	4	00 H
DATA VALUE (High Byte)	5	00 H
DATA VALUE (Low Byte)	6	C8 H
CHECKSUM (High Byte)	7	89 H
CHECKSUM (Low Byte)	8	6C H

The reply format is a copy of the command confirming its validity:

**NOTE:** This Modbus command is limited to writing 2-byte data only. Long Integer registers may be written but the meter assumes sets upper bytes automatically to zero.

## 5.5.10 Function 08 Loop Back Diagnostic

### Description

This function provides a simple means of testing the communication network and detecting if a particular meter is present. This command is not available as a *broadcast* command as it requires a return data packet from the meter.

### Host Request

	BYTE	EXAMPLE
METER ADDRESS	1	19 H
FUNCTION	2	08 H
DIAGNOSTIC CODE (High Byte)	3	00 H
DIAGNOSTIC CODE (Low Byte)	4	00 H
DIAGNOSTIC DATA (High Byte)	5	03 H
DIAGNOSTIC DATA (Low Byte)	6	E8 H
CHECKSUM (High Byte)	7	E3 H
CHECKSUM (Low Byte)	8	6D H

The example above shows a command with a Loop Back Code of 0 and Diagnostic Data of 1000 (03H E8H). The meter accessed has a Modbus ID of 25 (19H).

## Meter Response

	BYTE	EXAMPLE
METER ADDRESS	1	19 H
FUNCTION	2	08 H
DIAGNOSTIC CODE (High Byte)	3	00 H
DIAGNOSTIC CODE (Low Byte)	4	00 H
DIAGNOSTIC DATA (High Byte)	5	03 H
DIAGNOSTIC DATA (Low Byte)	6	E8 H
CHECKSUM (High Byte)	7	E3 H
CHECKSUM (Low Byte)	8	6D H

The reply format is a copy of the command confirming its validity:

## 5.5.11 Function 16 Preset Multiple Registers

### Description

This function allows a number of registers in a meter table to be set, by the host, in a single operation. When broadcast (address=0) all meters on the network are addressed together but none reply.

### Host Request

	BYTE	EXAMPLE
METER ADDRESS	1	19 H
FUNCTION	2	10 H
TABLE NUMBER (Address High Byte)	3	0D H
TABLE OFFSET (Address Low Byte)	4	03 H
NUMBER OF DATA WORDS (N) (High Byte)	5	00 H
NUMBER OF DATA WORDS (N) (Low Byte)	6	03 H
NUMBER OF DATA BYTES (2N)	7	06 H
DATA BYTE 1	8	00 H
DATA BYTE 2	9	00 H
DATA BYTE 3	10	00 H
DATA BYTE 4	11	00 H
DATA BYTE 5	12	00 H
DATA BYTE 6	13	00 H
CHECKSUM (High Byte)	14	0C
CHECKSUM (Low Byte)	15	FB

The example above simultaneously writes 00 to all three peak hold voltage registers (V1 Peak Hold = Table 13, Offset 3). The meter accessed has a Modbus ID of 25 (19H).

## Meter Response

	BYTE	EXAMPLE
METER ADDRESS	1	19 H
FUNCTION	2	10 H
TABLE NUMBER (Address High Byte)	3	0D H
TABLE OFFSET (Address Low Byte)	4	03 H
NUMBER OF DATA WORDS (High Byte)	5	00 H
NUMBER OF DATA WORDS (Low Byte)	6	03 H
CHECKSUM (High Byte)	7	71 H
CHECKSUM (Low Byte)	8	7C H

The reply confirms the data address and amount of data received.

## 5.5.12 Exception Responses

When a host sends a query to an individual meter on the network it expects a normal response. In fact one of four possible events may occur as a result of the query:

- ◇ If the Options Unit receives the message with no communication errors, and can handle the query it will reply with a normal response.
- ◇ If the Options Unit does not receive the message due to a communication failure, no response will be returned and the host will eventually time-out.
- ◇ If the Options Unit receives the message but detects a communication error via its CRC, no response will be returned and the host will time-out.
- ◇ If the Options Unit receives the query with no communication errors but cannot handle the query (out of range data or address) the response will be an **Exception Response** informing the host of the nature of the error.

An Exception Response differs from a normal response in its Function Code and Data Fields.

### Exception Response

	BYTE	EXAMPLE
METER ADDRESS	1	19 H
FUNCTION	2	84 H
EXCEPTION CODE	3	02 H
CHECKSUM (High Byte)	4	42 H
CHECKSUM (Low Byte)	5	C6H

### EXCEPTION FUNCTION CODE

All normal function types have a most significant bit of 0 (< 80 Hex). In an Exception Response the meter sets the MSB to 1 (adds 80H to the received Function Type). The Function can therefore be used by the host to detect an Exception Response.

### DATA FIELD

In an Exception Response the data field is used only to return the type of error that occurred (***Exception Code***).

The MultiCube Options Unit utilises the following Exception Codes:

Code	Meaning
1	Data out of range
2	Table and/or offset out of range for this function
3	Odd number of Integers written to Long Integer registers
9	Communications from Option Module to meter has failed

## 5.6 Modbus Diagnostics LEDs

The MultiCube Options unit uses 3 LEDs to aid commissioning into a Modbus system. These indicators are also useful to check continued operation of the device.

The LEDs are intelligent indicators, which are illuminated under specific conditions as follows:

- VALID COMMAND*** Illuminated when a host command is received, surrounded by RTU frame breaks (ref 5.4.2) with the correct Modbus address.
- ERROR/EXCEPTION*** Illuminated when a Valid Command is received as above but a CRC Error (ref 5.4.2) or Exception Condition (ref 5.5.12) is detected.
- BUS ACTIVITY*** Illuminated whenever changes occur on the receive input pins of the module.

## 6. Specification

<b>Auxiliary Supply</b>	
<b>Option Module</b>	230vac or 110vac 50/60Hz ±15% Automatic voltage selection when inserted into MultiCube MultiCube MUST be rated to match either selection.
<b>Load</b>	3 VA Maximum
<b>Isolation</b>	2.5 kV continuous (Supply internally wired to MultiCube Auxiliary mains inputs)

<b>Modbus Serial Comms</b>	
<b>Bus Type</b> <b>RX Loading</b> <b>TX Drive</b>	RS422 / RS485 4/2 Wires + 0V. Half Duplex 1/4 Unit Load Per Options Module 32 Unit Loads
<b>Protocol</b>	Modbus RTU with 16 bit CRC. (JBUS compatible)
<b>Baud Rate</b>	4800, 9600 or 19200 user programmable
<b>Address</b>	User Programmable 1-247
<b>Speed</b> <b>Reply Time</b> <b>Max Data Packet</b> <b>Command Rate</b>	100ms maximum from command end to reply start Any complete Table (Energy, Instantaneous, set-up etc) New command within 5ms of previous one

## Mechanical (Options Module)

<b>Enclosure</b>	Custom Options Enclosure. Material Mablex UL94-V-0
<b>Dimensions</b> <b>Options Unit Unfitted</b> <b>MultiCube + Options</b>	W=87mm x H=59mm x L=75mm W=96mm x H=96mm x L= 138mm (130mm behind panel)
<b>Weight</b>	Approx. 200g
<b>Terminals</b>	Rising Cage. 0.2 - 4.0mm <sup>2</sup> Conductors

## General

<b>Temperature</b> <b>Operating</b> <b>Storage</b>	-10 deg C to +65 deg C -25 deg C to +70 deg C
<b>Environment</b>	IP40
<b>Humidity</b>	<75% non-condensing

Northern Design (Electronics) Ltd,  
228 Bolton Road, Bradford,  
West Yorkshire, BD3 0QW, England.  
Telephone: +44 (0) 1274 729533  
Fax: +44 (0) 1274 721074  
Email: [sales@ndmeter.co.uk](mailto:sales@ndmeter.co.uk)  
Or: [support@ndmeter.co.uk](mailto:support@ndmeter.co.uk)  
Copyright © Northern Design 2000

