

# **MultiCube Options**

## **Digital Input/Output Addendum**

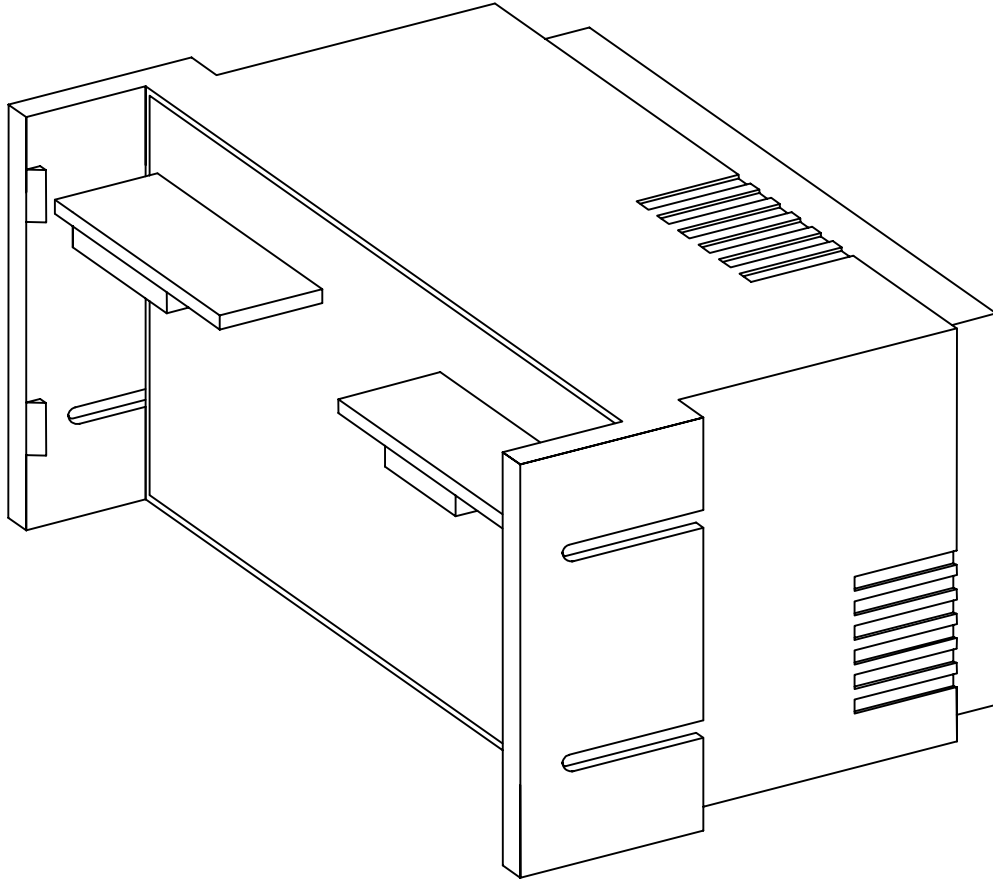

**July 2004**

**Installation and Operation**

# Inputs

---

## 1. Inputs

### 1.1 Description

Four independent digital inputs are provided which may be used as Digital Status or Accumulating Pulse Count inputs. The inputs are safety isolated at 2.5kV from the power metering circuits.

#### 1.1.1 Use As Pulse Accumulators

Each input may be derived from a volt free, normally open contact pair such as those found on modern utility meters. Four independent 32-Bit registers (max count 4,294,967,296) are provided which accumulate input pulses and store them in non-volatile memory. Each register may be read and/or written as registers in a Modbus data table.

#### 1.1.2 Use as Digital Inputs

Each input may be used as a Modbus discrete digital input. Standard Modbus commands may be used to read the digital status of each channel.

## 1.2 Inputs Connection

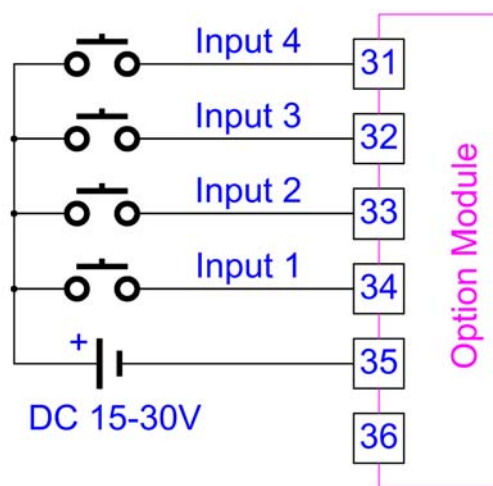

Figure 1-1 Input Connection

## 2. Outputs

### 2.1 Description

Three independent digital outputs are provided which may be used as control inputs to external switching devices.

Each output is individually isolated (50V Out – Out, 2.5kV Outputs – all other circuits) and takes the form of a normally open volt free contact pair.

Using normal Modbus commands, the status of each output may be set and/or read.

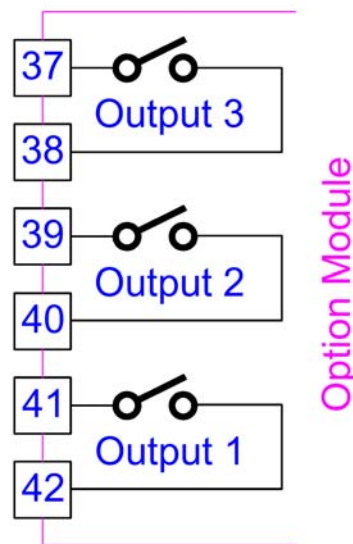

Figure 2-1 Output Schematic

**Note:** The outputs are of a NON-HOLDING type and will be reset to the OFF state in the event of a loss of auxiliary power to the meter.

## 3. Modbus Communications

### 3.1 Table 25 External Pulse Input Count Registers

Offset	Address	Contents	Format	Bytes	Words	Access
0	6400	Count 1 Hi	Unsigned Long	4	2	Read/Write
1	6401	Count 1 Lo				
2	6402	Count 2 Hi	Unsigned Long	4	2	Read/Write
3	6403	Count 2 Lo				
4	6404	Count 3 Hi	Unsigned Long	4	2	Read/Write
5	6405	Count 3 Lo				
6	6406	Count 4 Hi	Unsigned Long	4	2	Read/Write
7	6407	Count 4 Lo				

#### 3.1.1.1 External Pulse Input Count Registers

Pulse Input Count registers accumulate pulses from external sources via the Input/Output & Modbus options module. These registers may be used to record pulses from other pulsing devices such as gas, water steam meters etc. The four resultant 4-byte registers are stored in Modbus Table 25 as unsigned long integers.

#### 3.1.1.2 Reading Input Count Registers

Function 3 or 4 may be used to read the input count registers in Table 25. These Modbus commands are covered in full in “**MultiCube Options, Modbus Communications, Installation and Operation**”.

#### 3.1.1.3 Writing to Input Count Registers

Function 6 or 16 may be used to write to the Input Count registers in Table 25. These Modbus commands are covered in full in “**MultiCube Options, Modbus Communications, Installation and Operation**”.

Function 6 allows access to the upper and lower integers of the 4-byte long individually. Function 16 may be used to access a number of long integers using a single command. This is most useful for setting all registers to 0 simultaneously. Valid commands must send an even number of integers (2 integers per long) starting at an even address in Table 25 (Start of a register). Failure to follow these basic rules will result in an exception response.

## 3.2 Additional RTU Commands

### 3.2.1 Modbus Coils

The Modbus protocol was written with programmable controllers in mind and much of the terms used are derived from this market. The term **Coil** is used widely in Modbus when referring to single bit control outputs. In the MultiCube Option Module we will use the term “Digital Output” in place of the term Coil.

### 3.2.2 Modbus Inputs

The term **Input** is used in Modbus when referring to single bit control inputs. In the MultiCube Option Module we will use the term “Digital Input” in place of the term Input.

# Modbus Communications

---

## 3.2.3 Function 01 Read Digital Output Status

### Description

This function reads the ON/OFF status of the Digital Outputs. This command is not available as a *broadcast* command as it requires a return data packet from the meter.

### Host Request

	BYTE	EXAMPLE
METER ADDRESS	1	19H
FUNCTION	2	01H
First Digital Output Address Hi	3	00H
First Digital Output Address Lo	4	00H
No. of Points (High Byte)	5	00H
No. of Points (Low Byte)	6	03H
CHECKSUM (High Byte)	7	7FH
CHECKSUM (Low Byte)	8	D3H

The MultiCube has only 3 digital outputs addresses 00H, 01H and 02H.

Byte 3 of the Host Request should always be 00H.

Byte 4 of the host request must be equal to 00H, 01H or 02H depending on the first output required.

The number of points requested must be less than or equal to 3 and sent as byte 6 in the host request. Byte 5 must always be zero.

## Meter Response

	BYTE	EXAMPLE
METER ADDRESS	1	19H
FUNCTION	2	01H
NUMBER OF BYTES	3	01H
Digital Output Bits	4	00000111
CHECKSUM (High Byte)	5	16H
CHECKSUM (Low Byte)	6	EAH

The number of bytes will always be 01H for the MultiCube as the unit contains only 3 digital outputs (3-Bits)

### Digital Output Bits

The LSB of the **Digital Output Bits** data byte contains the status of the first Digital Output requested as: 1=ON/CLOSED, 0=OFF/OPEN.

The next two significant bits represent the status of the next two Digital Outputs if requested.

The most significant bits not used to represent Digital Output status are set to zero.

# Modbus Communications

---

## **Example 1**

### **Request**

First Digital Output Address	00H, 00H
Number of Points	00H, 03H

### **Reply**

0	0	0	0	0	S3	S2	S1
---	---	---	---	---	----	----	----

Digital Output Bits

Where Sn represents the status of Digital Output n.  
1=ON/CLOSED, 0=OFF/OPEN

## **Example 2**

### **Request**

First Digital Output Address	00H, 01H
Number of Points	00H, 02H

### **Reply**

0	0	0	0	0	0	S3	S2
---	---	---	---	---	---	----	----

Digital Output Bits

## **Example 3**

### **Request**

First Digital Output Address            00H, 00H  
Number of Points                         00H, 01H

### **Reply**

0	0	0	0	0	0	0	S1
---	---	---	---	---	---	---	----

Digital Output Bits

## **Example 4**

### **Request**

First Digital Output Address            00H, 02H  
Number of Points                         00H, 01H

### **Reply**

0	0	0	0	0	0	0	S3
---	---	---	---	---	---	---	----

Digital Output Bits

# Modbus Communications

---

## 3.2.4 Function 02 Read Digital Input Status

### Description

This function reads the ON/OFF status of the Digital Inputs. This command is not available as a *broadcast* command as it requires a return data packet from the meter.

### Host Request

	BYTE	EXAMPLE
METER ADDRESS	1	19H
FUNCTION	2	02H
First Digital Input Address Hi	3	00H
First Digital Input Address Lo	4	00H
No. of Points (High Byte)	5	00H
No. of Points (Low Byte)	6	04H
CHECKSUM (High Byte)	7	7AH
CHECKSUM (Low Byte)	8	11H

The MultiCube has only 4 digital inputs addresses 00H, 01H, 02H and 03H.

Byte 3 of the Host Request should always be 00H.

Byte 4 of the host request must be equal to 00H, 01H, 02H or 03H depending on the first digital input required in the reply.

The number of points requested must be less than or equal to 4 and sent as byte 6 in the host request. Byte 5 must always be zero.

## Meter Response

	BYTE	EXAMPLE
METER ADDRESS	1	19H
FUNCTION	2	02H
NUMBER OF BYTES	3	01H
Digital Input Bits	4	00001111
CHECKSUM (High Byte)	5	E7H
CHECKSUM (Low Byte)	6	2CH

The number of bytes will always be 01H for the MultiCube as the unit contains only 4 digital inputs (4-Bits)

### Digital Input Bits

The LSB of the **Digital Input Bits** data byte contains the status of the first Digital Input requested as: 1=ON/CLOSED, 0=OFF/OPEN.

The next three significant bits represent the status of the next three Digital Inputs if requested.

The most significant bits not used to represent Digital Input status are set to zero.

# Modbus Communications

---

## Example 1

### Request

First Digital Input Address	00H, 00H
Number of Points	00H, 04H

### Reply

0	0	0	0	i4	i3	i2	i1
---	---	---	---	----	----	----	----

Digital Input Bits

Where " $i_n$ " represents the status of Digital Input n.  
1=ON/CLOSED, 0=OFF/OPEN

## Example 2

### Request

First Digital Input Address	00H, 01H
Number of Points	00H, 02H

### Reply

0	0	0	0	0	0	i3	i2
---	---	---	---	---	---	----	----

Digital Input Bits

## **Example 3**

### **Request**

First Digital Input Address	00H, 00H
Number of Points	00H, 01H

### **Reply**

0	0	0	0	0	0	0	i1
---	---	---	---	---	---	---	----

Digital Input Bits

## **Example 4**

### **Request**

First Digital Input Address	00H, 03H
Number of Points	00H, 01H

### **Reply**

0	0	0	0	0	0	0	i4
---	---	---	---	---	---	---	----

Digital Input Bits

# Modbus Communications

---

## 3.2.5 Function 05 Force Single Digital Output

### Description

This function forces a single Digital Output to the ON or OFF status. When broadcast the function forces the same Digital Output in all slaves.

### Host Request

	BYTE	EXAMPLE
METER ADDRESS	1	19H
FUNCTION	2	05H
Digital Output Address Hi	3	00H
Digital Output Address Lo	4	00H
Force Data Hi	5	FFH
Force Data Lo	6	00H
CHECKSUM (High Byte)	7	8FH
CHECKSUM (Low Byte)	8	E2H

The MultiCube has only 3 digital outputs at addresses 00H, 01H and 02H. Byte 3 of the Host Request should always be 00H.

### Force Data Hi:Lo

To Force a Digital Output to ON

Hi:Lo = FF:00

To Force a Digital Output to OFF

Hi:Lo = 00:00

All other values of Hi:Lo will leave the status of the Digital Output unaffected.

## Meter Response

	BYTE	EXAMPLE
METER ADDRESS	1	19H
FUNCTION	2	05H
Digital Output Address Hi	3	00H
Digital Output Address Lo	4	00H
Force Data Hi	5	FFH
Force Data Lo	6	00H
CHECKSUM (High Byte)	7	8FH
CHECKSUM (Low Byte)	8	E2H

The normal response is an echo of the host request, returned after the Digital Output state has been forced.

# Modbus Communications

---

## 3.2.6 Function 15 Force Multiple Digital Outputs

### Description

This function forces a each Digital Output in a sequence to the ON or OFF state. When broadcast the function forces the same Digital Outputs in all slaves.

### Host Request

	BYTE	EXAMPLE
METER ADDRESS	1	19H
FUNCTION	2	0FH
Digital Output Address Hi	3	00H
Digital Output Address Lo	4	00H
Number of Points Hi	5	00H
Number of Points Lo	6	03H
Byte Count	7	01H
Force Data Bits	8	00H
CHECKSUM (High Byte)	9	8FH
CHECKSUM (Low Byte)	10	FDH

The MultiCube has only 3 digital outputs at addresses 00H, 01H and 02H.

Byte 3 of the Host Request should always be 00H.

Byte 4 of the host request must be equal to 00H, 01H or 02H depending on the address of the first output to be forced.

The number of points requested must be less than or equal to 3 and sent as byte 6 in the host request. Byte 5 must always be zero.

The byte count field is always set to 01H for the MultiCube as only 1 byte of data is required to set the 3 Digital Outputs.

To force a Digital Output to ON (CLOSED) set the corresponding bit to 1.

To force a Digital Output to OFF (OPEN) set the corresponding bit to 0.

## Meter Response

	BYTE	EXAMPLE
METER ADDRESS	1	19H
FUNCTION	2	0FH
Digital Output Address Hi	3	00H
Digital Output Address Lo	4	00H
Number of Digital Outputs Hi	5	00H
Number of Digital Outputs Lo	6	03H
CHECKSUM (High Byte)	7	52H
CHECKSUM (Low Byte)	8	0EH

The normal response is returned after the Digital Output states have been forced.

### **Example 1**

Set Digital Outputs as:

Digital Output 1 (Addr=00H) = ON

Digital Output 2 (Addr=01H) = ON

Digital Output 3 (Addr=02H) = ON

### **Request**

Digital Output Address	00H, 00H
Number of Points	00H, 03H
Byte Count	01H

### **Force Data**

0	0	0	0	0	1	1	1
---	---	---	---	---	---	---	---

Force Data = 07H

Note: Unused bits in the Force Data byte must be set to 0.

# Modbus Communications

---

## **Example 2**

Set Digital Outputs as:

Digital Output 2 (Addr=01H) = ON  
Digital Output 3 (Addr=02H) = OFF

### **Request**

Digital Output Address	00H, 01H
Number of Points	00H, 02H
Byte Count	01H

### **Force Data**

0	0	0	0	0	0	0	1
---	---	---	---	---	---	---	---

Force Data = 03H

Note: Unused bits in the Force Data byte must be set to 0.

## **Example 3**

Set Digital Outputs as:

Digital Output 3 (Addr=02H) = ON

### **Request**

Digital Output Address	00H, 02H
Number of Points	00H, 01H
Byte Count	01H

### **Force Data**

0	0	0	0	0	0	0	1
---	---	---	---	---	---	---	---

Force Data = 01H

Note: Unused bits in the Force Data byte must be set to 0.

## 4. Specification

These specifications are provided as an addendum to those in the “*MultiCube Options, Modbus Communications, Installation and Operation*” booklet.

<b>Digital Inputs</b>	
<b>Minimum ON Voltage</b>	10V dc.
<b>Maximum Input</b>	30V dc. Max
<b>Overload</b>	60V max 2 seconds
<b>Input Load</b>	10mA @ 24V DC
<b>Isolation</b>	2.5kV Inputs to all other circuits
<b>Pulse ON Time</b>	25ms Minimum
<b>Pulse OFF Time</b>	25ms Minimum
<b>Pulse Rate</b>	10hz Maximum

<b>Digital Outputs</b>	
<b>Function</b>	Status Controlled by Modbus functions 5 and 15 Status Read by Modbus function 2
<b>Type</b> <b>Contacts</b>	Non-Holding, Volt free N/O contacts. Optically isolated BIFETs 100mA AC/DC max. 100V AC/DC max
<b>Isolation</b>	2.5kV Outputs to all other circuits 50V Output to Output



Northern Design (Electronics) Ltd,  
228 Bolton Road, Bradford,  
West Yorkshire, BD3 0QW, England.  
Telephone: +44 (0) 1274 729533  
Fax: +44 (0) 1274 721074  
Email: [sales@ndmeter.co.uk](mailto:sales@ndmeter.co.uk)  
Or: [support@ndmeter.co.uk](mailto:support@ndmeter.co.uk)  
Copyright © Northern Design 2004

Mmm-YY Q K P