

MultiCube

Installation and Operation

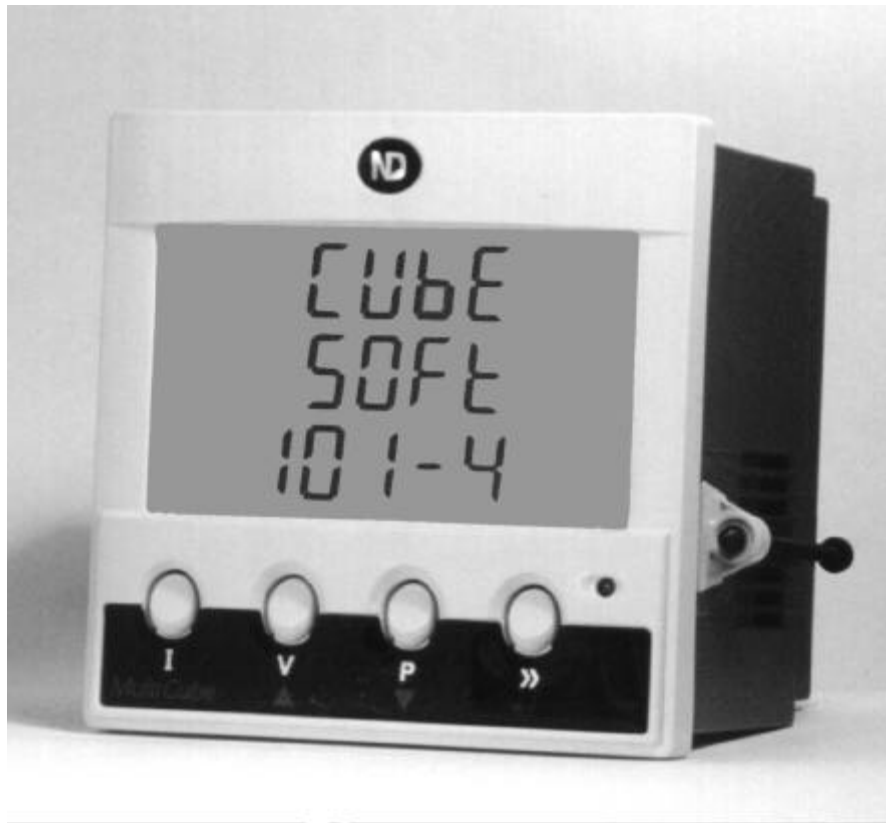

PREFACE

<p>MultiCube Operating Guide Revision 1.04 March 2000</p>
--

This manual represents your meter as manufactured at the time of publication. It assumes standard software. Special versions of software may be fitted, in which case you will be provided with additional details.

Every effort has been made to ensure that the information in this manual is complete and accurate. We revised this manual but cannot be held responsible for errors or omissions.

The apparatus has been designed and tested in accordance with EN 61010-1, 'Safety Requirements for Electrical Equipment for Measurement, Control and Laboratory Use'. This operating guide contains information and warnings which must be followed by the user to ensure safe operation and to maintain the apparatus in a safe condition.

We reserve the right to make changes and improvements to the product without obligation to incorporate these changes and improvements into units previously shipped.

General Editor : Ian Sykes BSc (hons).

Copyright © 2000 : Northern Design (Electronics) Ltd,
228 Bolton Road, Bradford. West Yorkshire. UK.

Table Of Contents

1.	Safety	4
1.1	Warning Symbols.....	4
1.2	Maintenance.....	4
2.	Meter Operation	5
2.1	Measurements.....	5
2.1.1	<i>Balance Current Measurements</i>	5
2.1.2	<i>Rolling Demand (V, I and kW Demand)</i>	6
2.2	Meter Types.....	7
2.3	Power Up.....	7
2.4	Display Pages.....	7
2.5	Display Scaling.....	17
2.5.1	<i>Voltage Scaling (Phase, Peak, MD, Pk MD)</i>	17
2.5.2	<i>Line-Line Voltage Scaling (V_{L-L})</i>	17
2.5.3	<i>Current Scaling (Phase, Peak, In, MD, Pk MD)</i>	17
2.5.4	<i>Per Phase & System Power Scaling (W, VA, var)</i>	18
2.5.5	<i>Energy Registers (Wh, VAh, varh)</i>	18
2.5.6	<i>Miscellaneous (Frequency, PF)</i>	18
2.6	Energy Register Reset.....	19
2.7	Peak Voltage Reset.....	19
2.8	Peak Current Reset.....	19
2.9	Peak Demand Reset.....	19
2.10	Isolated Pulse Outputs.....	20
3.	Installation	21
3.1	Panel Mounting.....	21
3.2	CT Connections.....	22
3.3	Voltage Connections.....	22
3.4	Auxiliary Mains Supply (L & N).....	23
3.5	Connection Schematics.....	24
4.	Programming	27
4.1	Description.....	27
4.2	Entering and Exiting Programming Mode.....	27
4.3	Setting The CT Primary Current.....	28
4.4	Setting The PT Primary Voltage.....	29
4.5	Setting Pulse Output 1 Rate.....	30
4.6	Setting Pulse Output 2 Rate.....	31
4.7	Setting The Ampere/Voltage Demand Period.....	32
4.8	Setting The kW Rolling Average Period.....	33
5.	Options Module	34
5.1	Description.....	34
6.	Specification	35

Safety

1. Safety

1.1 Warning Symbols

This manual provides details of safe installation and operation of the meter. Safety may be impaired if the instructions are not followed. Labels on individual meters give details of equipment ratings for safe operation. Take time to examine all labels on the meter and to read this manual before commencing installation.

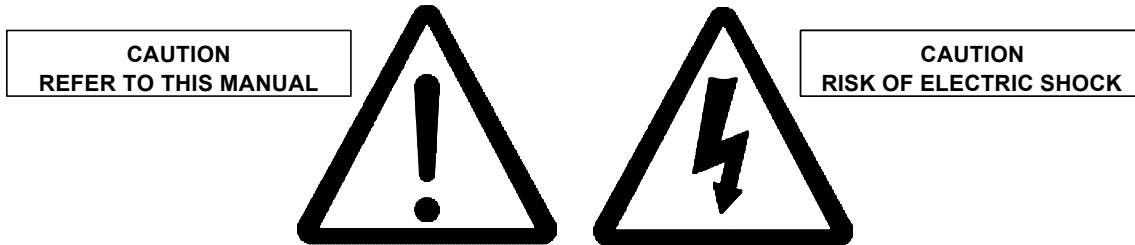

Figure 1.1 Safety Symbols

WARNING
The meter contains no user serviceable parts. Installation and commissioning should be carried out by qualified personnel

1.2 Maintenance

The equipment should be maintained in good working order. Damage to the product should be repaired by the manufacturer. The meter may be cleaned by wiping lightly with a soft cloth. No solvents or cleaning agents should be used. All inputs and supplies must be isolated before cleaning any part of the equipment.

2. Meter Operation

2.1 Measurements

The MultiCube makes use of a high speed micro-processor and an Analogue to Digital converter to monitor input signals from three independent phases. Each phase voltage, current and power (kW) are measured directly and a number of other parameters derived from these in software. The measurement process is continuous with all six signals scanned simultaneously at high speed. Unlike many other sampling systems, which sample one phase after another, this ensures that all input cycles are detected. Distorted input waveforms, with harmonics to the 20th are therefore detected accurately.

Derived parameters are calculated and displayed once a second, scaled by user programmed constants for current and voltage transformers.

Instantaneous power parameters are integrated over long time periods providing a number of energy registers. System frequency is detected by digital processing of the phase 1 voltage signal.

2.1.1 Balance Current Measurements

The rms. value of the instantaneous sum of the three phase currents is available on some MultiCube meter types. The total current in a three phase system may be represented as :

$$I_{bal} = I_1 + I_2 + I_3 = I_{LEAK} + I_n$$

I_{LEAK} represents any current leaving the system (e.g. Leakage to earth)

I_n represents current in the neutral (4 wire systems only)

NOTE In 3-Phase 3-Wire systems the MultiCube must be wired using 3 CTs as shown in Figure 3.3 for balanced current measurements to be made.

Meter Operation

2.1.2 Rolling Demand (V, I and kW Demand)

Average values of volts, Amps and kW (if fitted) are calculated over a user programmable time period (10 - 2500 seconds for V and I, 1 - 60 minutes for kW). The displays show the averages for the most recent time period ending at the time the display was last updated. The demand period is continuously updated as time progresses hence the term "**Rolling Demand**".

2.1.2.1 Calculating Rolling Demand

Each user set time period is split into smaller sub-periods (10 for V and I, 15 for kW). An average value for measurements taken every second during a sub-period are calculated for each parameter. The most recent 10 (15 for kW) sub-period averages are stored in memory as an array. An average of the data in each of these arrays is displayed as MD (rolling demand).

On power up (or after a brown-out) the sub-period array values are reset to zero. During the first full MD period the Rolling Demand value will accumulate as the zeroes are replaced with valid sub-period averages.

2.1.2.2 Peak Demand (kW, V and I Pk)

Peak MD readings are the maximum recorded values of corresponding Rolling Demand values.

These may be used to determine the maximum load requirement of a system. They are often used to determine spare capacity in a supply system, supply plant requirement etc.

On power failure or brown-out Peak Demand values are automatically saved in non-volatile memory within the MultiCube. The memory requires no battery and will hold the value for up to 10 years in the absence of mains power.

2.2 Meter Types

Four Standard MultiCube meter types are available to suit a range of applications. The meter type defines a number of display pages which may be selected and the parameters metered. This manual covers all meters independent of type.

2.3 Power Up

On power up the MultiCube shows the meter type and software issue. The example below shows software issue 1.04 meter type 3

CubE
SOft
104-3

2.4 Display Pages

To select current measurements press the **I** key repeatedly until the desired page is displayed. The number of pages available is dependant on meter type.

To select voltage measurements press the **V** key repeatedly until the desired page is displayed. The number of pages available is dependant on meter type.

To select power/energy measurements press the **P** key repeatedly until the desired page is displayed. The number of pages available is dependant on meter type.

Automatically scrolling pages showing PF, Volts & Amps on each phase are obtained by pressing >> once. This is available on all meter types.

Display pages available on the full range of MultiCube meters are shown below followed by tables showing those available on each standard meter type.

Meter Operation

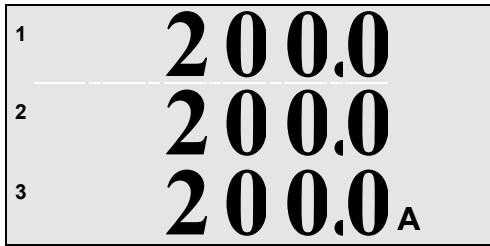

Phase Currents

Instantaneous true rms. current on phases 1, 2 and 3, scaled by user programmable CT primary.

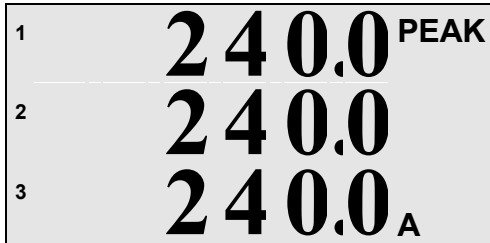

Peak Hold Currents

The largest instantaneous reading of phase 1, 2 and 3 currents (above) individually recorded since last reset.



Balance Current

The true rms. sum of the three instantaneous current waveforms scaled as phase current above. This is equivalent to neutral current in a three phase 4-wire system.

1	230.0
2	230.0 _v
3	230.0

Phase Voltages

Instantaneous true rms. voltages on phases 1, 2 and 3 with respect to neutral. These readings are scaled by user programmable PT primary.

1	398.4
2	398.4 _{V_{L-L}}
3	398.4

Line-Line Voltages

Instantaneous true rms. line to line voltages scaled by user programmable PT primary.

1=Line1-Line2

2=Line2-Line3

3=Line3-Line1

	276.0 ^{PEAK}
	276.0 _v
	276.0

Peak Hold Voltages

The largest instantaneous readings of phase voltages (above) individually recorded since last reset.

Meter Operation

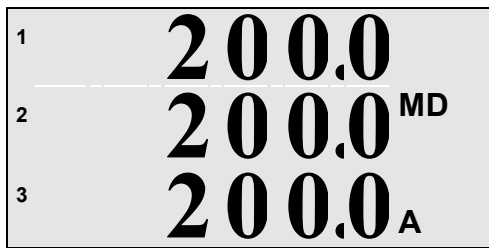

Ampere Demand

MD based on rolling averages of per phase Amps
User programmable sub-period 10s to 2500s
Average based 10 sub-period values (1s to 250s)
Display updated at the end of each sub period

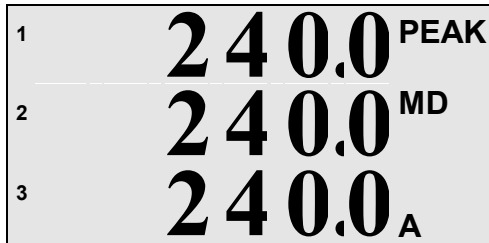

Peak Ampere Demand

The largest reading of per phase Ampere Demand values (above) recorded since last reset.
Display updated at the end of each sub period

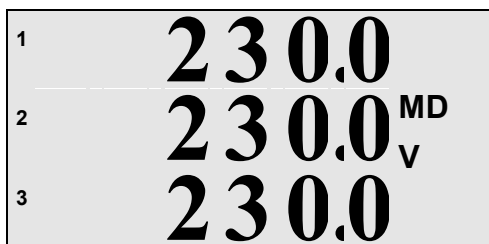

Voltage Demand

MD based on rolling averages of per phase Volts
Programmable sub-period as Ampere Demand
Average based 10 sub-period values (1s to 250s)
Display updated at the end of each sub period

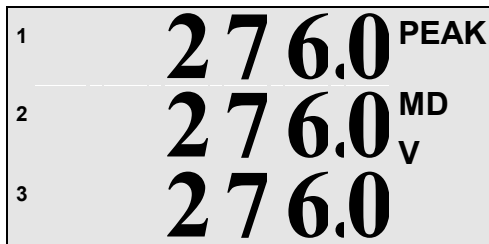

Peak Voltage Demand

The largest reading of Voltage Demand values (above) recorded since last reset.
Display updated at the end of each sub period

1	46.00
2	46.00
3	46.00 kW

Phase Watts

Instantaneous true rms. watts on phases 1,2 & 3, scaled by user programmable CT and PT values.

1	46.00
2	46.00
3	46.00 kVA

Phase VA

Per phase instantaneous VA calculated as :

$$VA_1 = V_1 \times I_1$$

$$VA_2 = V_2 \times I_2$$

$$VA_3 = V_3 \times I_3$$

Where V_x and I_x are rms. values.

1	39.84
2	39.84
3	39.84 kVAr

Phase var

Per phase instantaneous var calculated as :

$$\text{var}_1 = \sqrt{(VA_1^2 - W_1^2)}$$

$$\text{var}_2 = \sqrt{(VA_2^2 - W_2^2)}$$

$$\text{var}_3 = \sqrt{(VA_3^2 - W_3^2)}$$

Capacitive var shown as negative

	48.00 PEAK
	46.00 MD
	46.00 kW

kW Rolling Maximum Demand

MD based on rolling average of system kW :

Peak kW MD (largest since last reset)

Current Period kW MD

Instantaneous kW

Meter Operation

1.000 PF
50.0 hz
138.00 kW

System PF, Hz, W

3-Phase Power Factor ('-' denotes capacitive).
Frequency measured on phase 1 voltage.
3-Phase instantaneous Watts calculated as $W_1+W_2+W_3$

1.000 PF
50.0 hz
138.00 kVA

System PF, Hz, VA

3-Phase Power Factor ('-' denotes capacitive).
Frequency measured on phase 1 voltage.
3-Phase instantaneous VA calculated as $VA_1+VA_2+VA_3$

0.500 PF
50.0 hz
119.51 kVAr

System PF, Hz, var

3-Phase Power Factor ('-' denotes capacitive).
Frequency measured on phase 1 voltage.
3-Phase instantaneous var calculated as $var_1+var_2+var_3$

9999.9 kWh

Wh Register

System watts integrated over time to give accumulating, import, watt-hours.

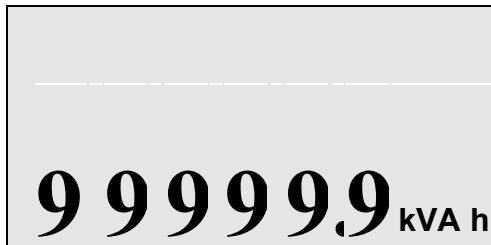

9 9 9 9 9,9 kVA h

VAh Register

System VA integrated over time to give accumulating, import, volt-ampere-hours.

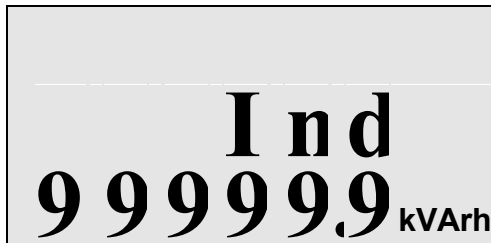

Ind
9 9 9 9 9,9 kVArh

Inductive varh Register

System var integrated over time is accumulated in this register while the load measured is inductive.

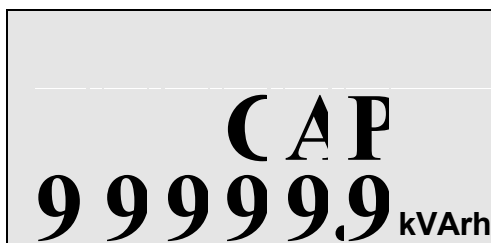

CAP
9 9 9 9 9,9 kVArh

Capacitive varh Register

System var integrated over time is accumulated in this register while the load measured is capacitive (displayed as negative).

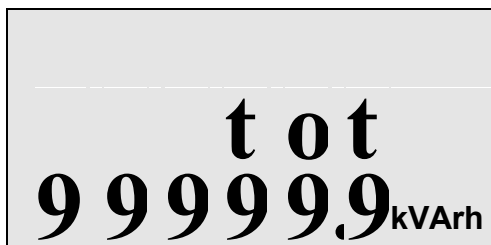

tot
9 9 9 9 9,9 kVArh

Total varh Register

The absolute sum of Inductive + Capacitive varh

Meter Operation

	1.000	PF
PHASE	230.0	V
1	200.0	A

Phase 1 PF, Volts & Amps

Phase 1 PF ('-' denotes capacitive).

Phase 1 Voltage scaled as above

Phase 1 Current scaled as above

	1.000	PF
PHASE	230.0	V
2	200.0	A

Phase 2 PF, Volts & Amps

Phase 2 PF ('-' denotes capacitive).

Phase 2 Voltage scaled as above

Phase 2 Current scaled as above

	1.000	PF
PHASE	230.0	V
3	200.0	A

Phase 3 PF, Volts & Amps

Phase 3 PF ('-' denotes capacitive).

Phase 3 Voltage scaled as above

Phase 3 Current scaled as above

MultiCube Type 1 Menus			
I	V	P	>>
Phase Currents	Phase Voltages	System PF, Hz, W	Phase 1 PF, V, I
Ampere Demand	Line-Line Voltages	Phase Watts	Phase 2 PF, V, I
Pk Ampere Demand	Voltage Demand		Phase 3 PF, V, I
	Pk Voltage Demand		

MultiCube Type 2 Menus			
I	V	P	>>
Phase Currents	Phase Voltages	System PF, Hz, W	Phase 1 PF, V, I
Ampere Demand	Line-Line Voltages	Phase Watts	Phase 2 PF, V, I
Pk Ampere Demand	Voltage Demand	Wh Register	Phase 3 PF, V, I
	Pk Voltage Demand		

MultiCube Type 3 Menus			
I	V	P	>>
Phase Currents	Phase Voltages	System PF, Hz, W	Phase 1 PF, V, I
Ampere Demand	Line-Line Voltages	System PF, Hz, var	Phase 2 PF, V, I
Pk Ampere Demand	Voltage Demand	Phase Watts	Phase 3 PF, V, I
	Pk Voltage Demand	Phase var	
		Peak MD, Rolling MD, kW	
		Wh Register	
		Total varh Register	
		Inductive varh Register	
		Capacitive varh Register	

Meter Operation

MultiCube Type 4 Menus			
I	V	P	>>
Phase Currents	Phase Voltages	System PF, Hz, W	Phase 1 PF, V, I
Peak Hold Currents	Line-Line Voltages	System PF, Hz, VA	Phase 2 PF, V, I
Neutral Current	Peak Hold Voltages	System PF, Hz, var	Phase 3 PF, V, I
Ampere Demand	Voltage Demand	Phase Watts	
Pk Ampere Demand	Pk Voltage Demand	Phase VA	
		Phase var	
		Peak MD, Rolling MD, kW	
		Wh Register	
		VAh Register	
		Total varh Register	
		Inductive varh Register	
		Capacitive varh Register	

2.5 Display Scaling

The MultiCube scales its displays automatically to provide the optimum resolution dependant on user settings (CT and PT Primary). This provides direct reading of parameters with decimal points and legends automatically selected (e.g. kW or MW etc).

2.5.1 Voltage Scaling (Phase, Peak, MD, Pk MD)

PT Setting	Example Display
60V _{L-L} - 140V _{L-L}	20.00 V
141V _{L-L} - 1,400V _{L-L}	200.0 V
1,401V _{L-L} - 14,000V _{L-L}	2.000 kV
14,001V _{L-L} - 50,000V _{L-L}	20.00 kV

2.5.2 Line-Line Voltage Scaling (V_{L-L})

PT Setting	Example Display
60V _{L-L} - 80V _{L-L}	50.00 V _{L-L}
81V _{L-L} - 800V	500.0 V _{L-L}
801V _{L-L} - 8,000V _{L-L}	5.000 kV _{L-L}
8,001V _{L-L} - 50,000V _{L-L}	50.00 kV _{L-L}

2.5.3 Current Scaling (Phase, Peak, In, MD, Pk MD)

CT Setting	Example Display
5A - 8A	5.000 A
9A - 80A	50.00 A
81A - 800A	500.0 A
801A - 6,500A	5.000 kA

Meter Operation

2.5.4 Per Phase & System Power Scaling (W, VA, var)

PT Setting x CT Setting	Example Display
300VA - 1,400VA	200.0 W
1,401VA - 14,000VA	2.000 kW
14,001VA - 140,000VA	20.00 kW
140,001VA - 1,400,000VA	200.0 kW
1,400,001VA - 14,000,000VA	2000 kW
14,000,001VA - 140,000,000VA	20.00 MW
140,000,001VA - 250,000,000VA	200.0 MW

Note: Rolling kW Demand, Peak Demand and kW on the MD page are displayed with 1 less digit of resolution than those above. (e.g. 20.00 kW becomes 20.0 kW)

2.5.5 Energy Registers (Wh, VAh, varh)

PT Setting x CT Setting	Example Display
300VA - 1,400VA	999.999 kWh
1,401VA - 14,000VA	9999.99 kWh
14,001VA - 140,000VA	99999.9 kWh
140,001VA - 1,400,000VA	999999 kWh
1,400,001VA - 14,000,000VA	9999.99 MWh
14,000,001VA - 140,000,000VA	99999.9 MWh
140,000,001VA - 250,000,000VA	999999 MWh

2.5.6 Miscellaneous (Frequency, PF)

All Settings	Example Display
	1.000 PF
	50.0 Hz

2.6 Energy Register Reset

All accumulating energy registers may be simultaneously reset to zero using the front panel keys. Once reset, energy readings are lost forever so great care must be taken when using this feature. To reset all energy registers

- Select any energy display page as described above
- Press **P** and **>>** keys together and Hold for 5 seconds.

2.7 Peak Voltage Reset

The peak voltage readings may be simultaneously reset to zero using the front panel keys. Once reset the old values will be immediately replaced by the latest instantaneous readings and subsequent peaks as they occur. To reset Peak Voltages

- Select the Peak Voltage display page as described above
- Press **P** and **>>** keys together and Hold for 5 seconds.

2.8 Peak Current Reset

The peak current readings may be simultaneously reset to zero using the front panel keys. Once reset the old values will be immediately replaced by the latest instantaneous readings and subsequent peaks as they occur. To reset Peak Currents

- Select the Peak Current display page as described above
- Press **P** and **>>** keys together and Hold for 5 seconds.

2.9 Peak Demand Reset

Peak rolling demand readings (Volts, Amps or kW) may be reset to zero using the front panel keys. At the end of the next sub period the peak will be set to the latest rolling average value. To reset the Peak MD

- Select the Peak Ampere, Voltage or kW Demand display page as required
- Press **P** and **>>** keys together and Hold for 5 seconds.

Meter Operation

2.10 Isolated Pulse Outputs

MultiCube meters which display kWh and/or kvarh incorporate isolated pulse output(s). These outputs provide a simple interface to external systems such as building management centres etc.

Each output takes the form of a normally open, volt free contact pair which provides a low resistance, for 100mS, at the end of a pre-set number of increments of the associated energy register ('pulse rate'). The pulse rate of each output may be programmed by the user to match the requirements of the external system. For further details on programming the MultiCube refer to Section 4.

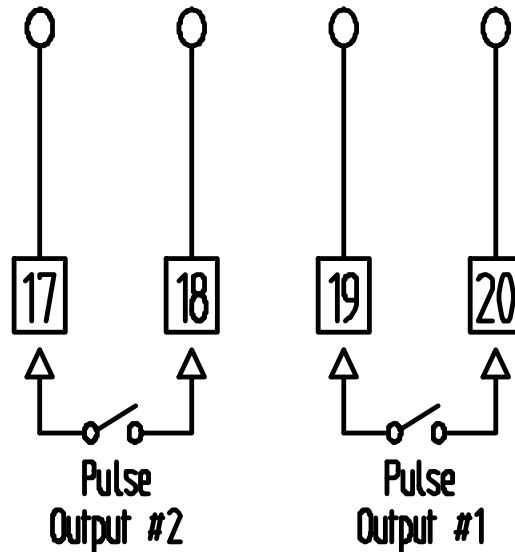

Figure 2.2 Pulse Output Connection

3. Installation

3.1 Panel Mounting

Panels should be of thickness 1mm to 4mm with a square cut-out of 92mm (+0.8 - 0.0). A minimum depth of 72mm should be allowed behind the panel for the meter. Remove the panel mounting clips and insert the meter into the cut-out from the front of the panel. Push the meter home. Ensure the screws in each panel mount clip are fully retracted and insert the clips as shown in the diagram below. Tighten the screws to secure the meter firmly in the panel.

DO NOT OVERTIGHTEN.

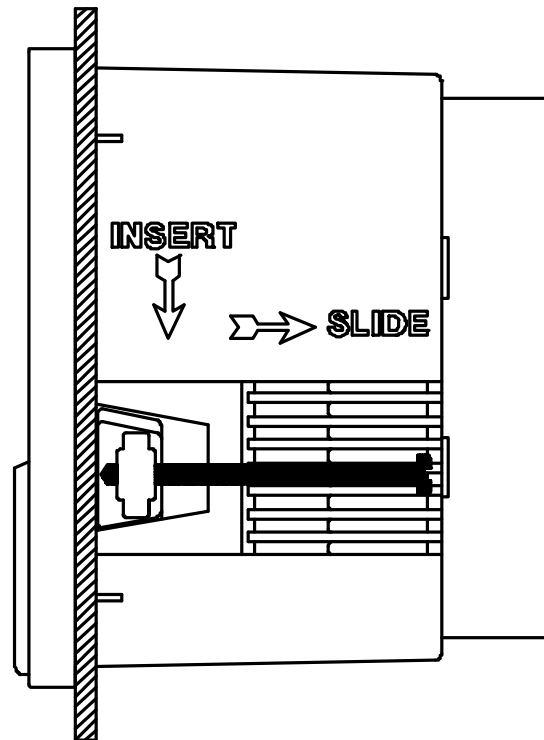

Figure 3.1 Fitting The Meter in a Panel

Installation

3.2 CT Connections

The MultiCube is designed for use with external current transformers (CTs). Recommended types should conform to Class 1 per IEC 60044-1. The secondary of the CT should be specified to suit the input rating defined on the meter label. Cables used for the current circuit should have a maximum conductor size of 4.0mm² and should be kept as short as possible to reduce cable losses loading the CT secondary. CT Inputs to the meter are isolated from each other and all other parts of the circuit. This allows use on a wide variety of systems including those requiring common and/or earthed CT secondaries.

WARNING :

NEVER leave the secondary of a current transformer open circuit while a primary current flows. In this condition dangerous voltages may be produced at the secondary terminals.

3.3 Voltage Connections

Cables used for the voltage measurement circuit should be insulated to a minimum of 600V AC and have a minimum current rating of 250mA. The maximum conductor size is 4.0mm².

External protection fuses are recommended for the voltage measurement inputs. These should be rated at 160mA maximum, Type F, and should be able to withstand voltages greater than the maximum input to the meter.

3.4 Auxiliary Mains Supply (L & N)

The MultiCube uses an isolated auxiliary mains supply separate from the voltage measurement inputs. This may be connected separately or in parallel with the measurement inputs provided the ratings detailed on the instrument label are not exceeded.

Separate connection of the auxiliary mains is required, for example, when :

- A suitable supply voltage is not available locally.
- Measurement voltages are expected to vary over a wide range
- A backup supply is required to maintain meter display

The auxiliary mains supply is internally fused at 250V, 100mA type T. External fusing is required if the auxiliary supply voltage exceeds 250V. The meter ratings are detailed on the instrument label.

WARNING :

CHECK the instrument **LABELS** for correct input ratings.
Incorrectly rated inputs may permanently damage the device

3.5 Connection Schematics

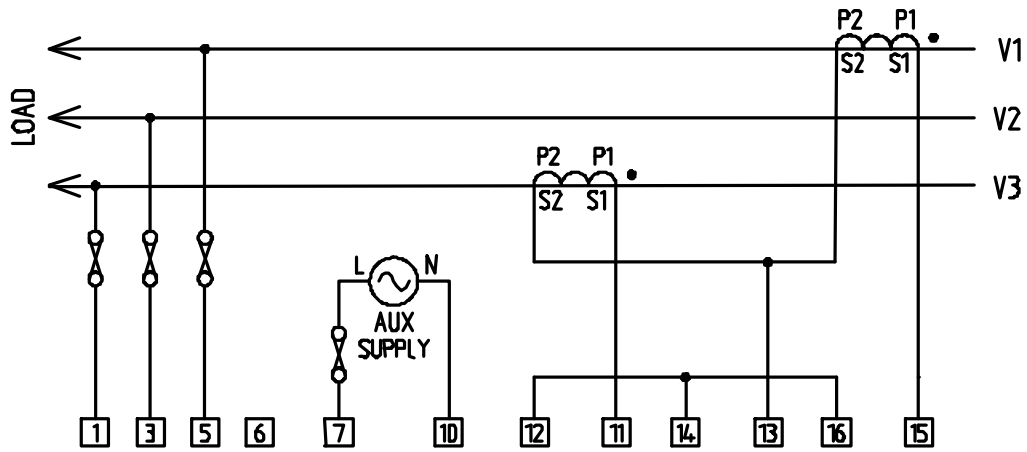

Figure 3.2 3-Phase 3-Wire 2CTs (Not Suitable For Neutral Current Measurements)

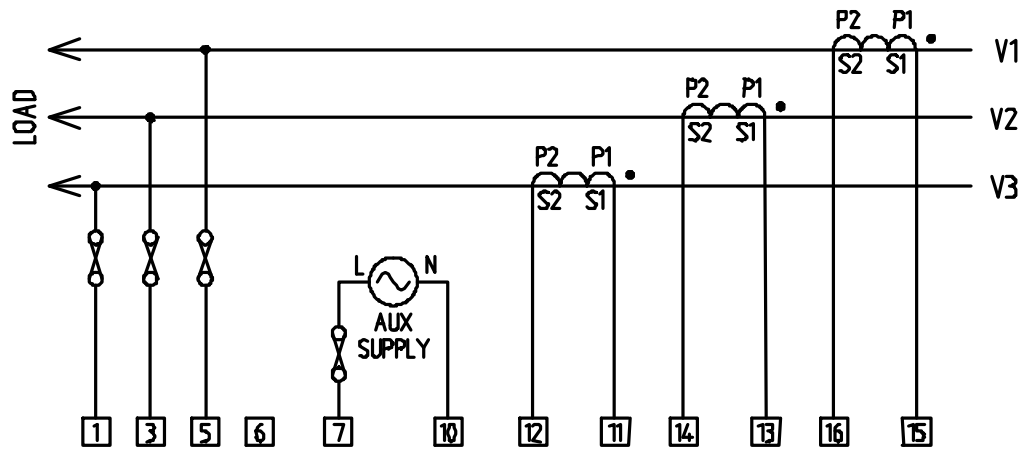

Figure 3.3 3-Phase 3-Wire 3CTs

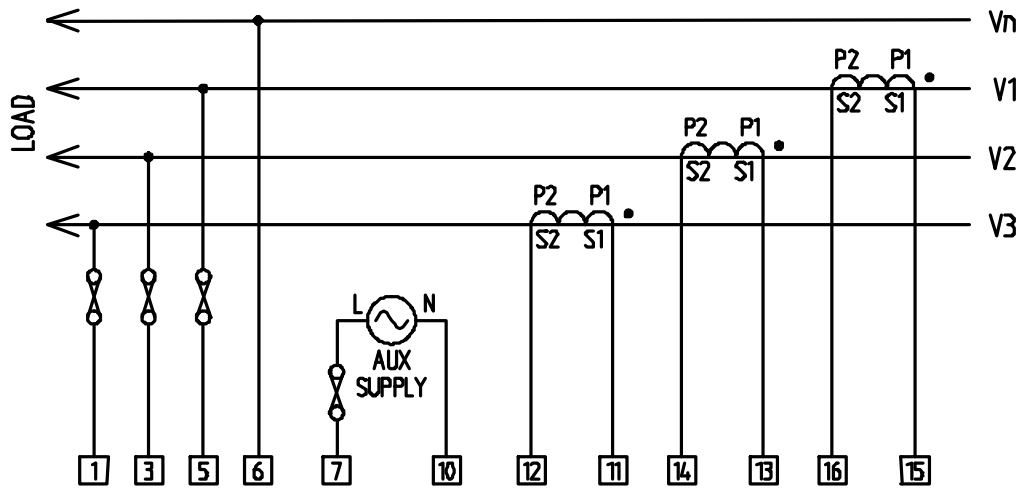

Figure 3.4 3-Phase 4-Wire

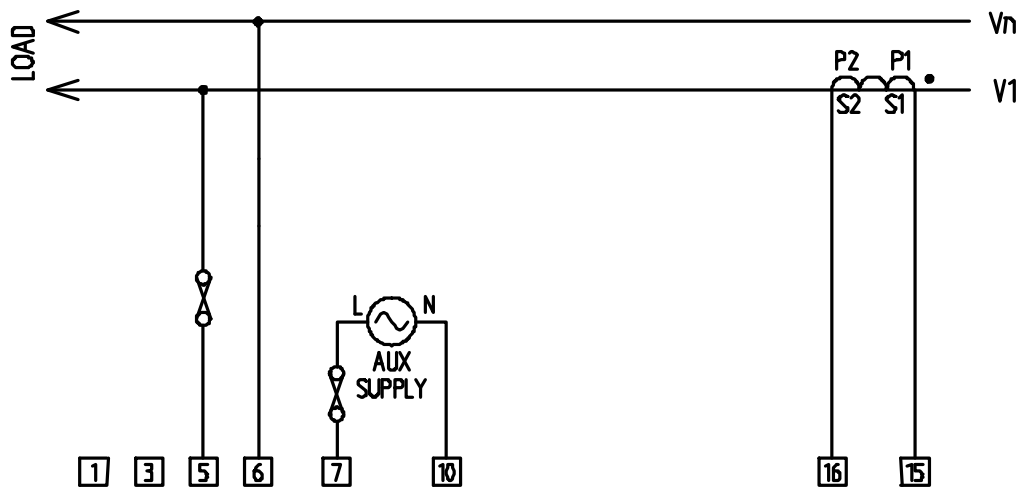

Figure 3.5 Single Phase

Installation

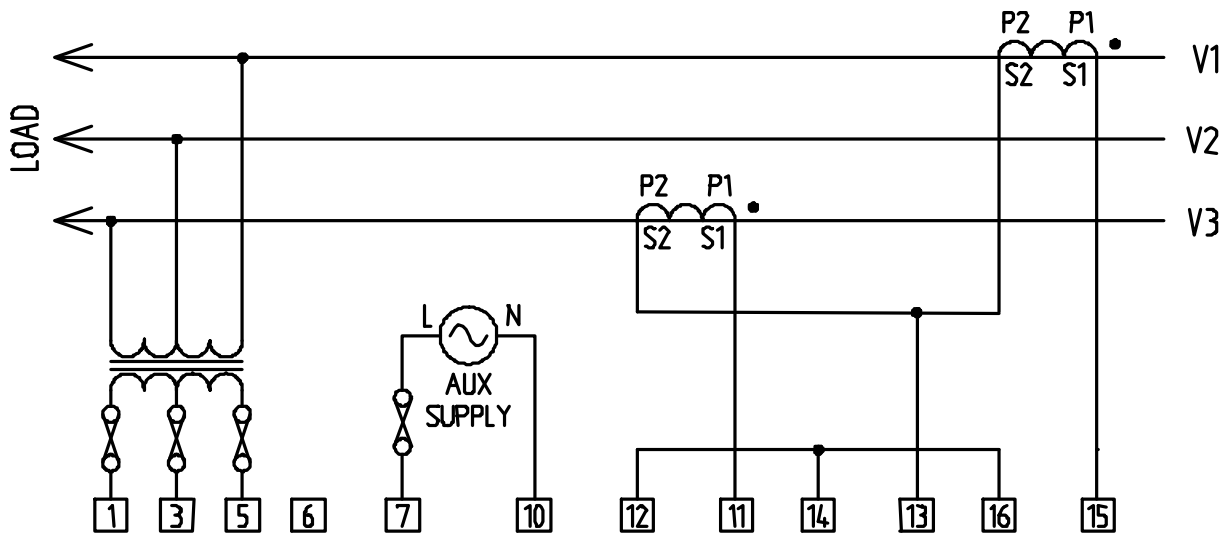

Figure 3.6 3 Phase 3 Wire Using Potential Transformers

4. Programming

4.1 Description

The MultiCube is designed for use in a wide variety of systems. A range of programmable features allow the unit to be set-up for a specific application. Programming is available using the front panel keypad and display while the unit is operational.

4.2 Entering and Exiting Programming Mode

To enter programming, Press **I** and **V** together and hold for 5 seconds.

When all user programmable settings are complete, Press **I** and **V** together and hold for 5 seconds to return to measurement mode.

Programming

4.3 Setting The CT Primary Current

The first item in the programming menu allows the user to set the CT Primary current, in the range 5A to 6500A, to match the primary of the current transformers connected to the meter inputs. The secondary of the CTs must match the nominal input current specified on the meter label. Once set, the constant acts as a multiplying factor in the internal calculation of relevant measurements.

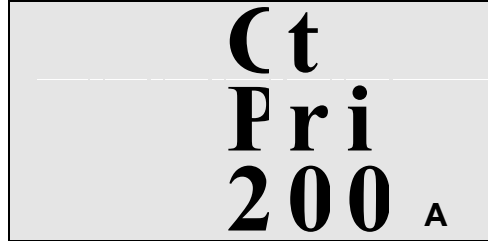

Figure 4.1 Setting The CT Primary Constant

Press Δ to increase the CT Primary Constant in steps of 1 Amp.

Press ∇ to decrease the CT Primary Constant in steps of 1 Amp.

Press ? and hold for 2 seconds when done.

4.4 Setting The PT Primary Voltage

The next item in the programming menu allows the user to set the PT Primary line-line voltage, in the range 60V to 50,000V, to match the primary of the potential transformers connected to the meter inputs. The secondary of the PTs must match the nominal line-line input voltage specified on the meter label. If no potential transformers are fitted the PT setting must match the nominal line-line input voltage specified on the meter label.

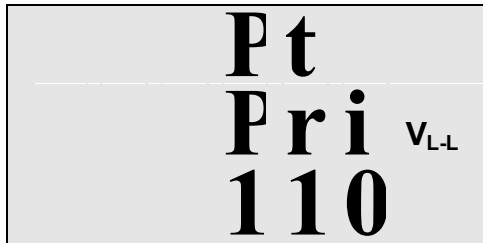

Figure 4.1 Setting The PT Primary Constant

Press Δ to increase the PT Primary Constant in steps of 1 Volt.

Press ∇ to decrease the PT Primary Constant in steps of 1 Volt.

Press ? and hold for 2 seconds when done.

4.5 Setting Pulse Output 1 Rate

Isolated pulse output #1 may be set to provide a single pulse at the end of every 1, 10, or 100 increments of the Wh register irrespective of display scaling and decimal point. This allows the unit to be configured to suit a wide variety of data logging, building management type applications.

During programming, the Pulse Output #1 Rate is displayed scaled as the Wh register for convenience. A display of **PL 1 rAtE 10.0 kWh** indicates that a single pulse will occur, at output #1, at the end of each 10 kWh.



PL 1
rAtE
10.0 kWh

Figure 4.2 Setting The Pulse Output #1 Rate

Press Δ to increase the Pulse Output Rate by a factor of 10.

Press ∇ to decrease the Pulse Output Rate by a factor of 10.

Press ? and hold for 2 seconds when done.

4.6 Setting Pulse Output 2 Rate

Isolated pulse output #2 may be set to provide a single pulse at the end of every 1, 10, or 100 increments of the Total varh register irrespective of display scaling and decimal point. This allows the unit to be configured to suit a wide variety of data logging, building management type applications.

During programming, the Pulse Output #2 Rate is displayed scaled as the total varh register for convenience. A display of **PL 2 rAtE 10.0 kVArh** indicates that a single pulse will occur, at output #2, at the end of each 10 kvarh.

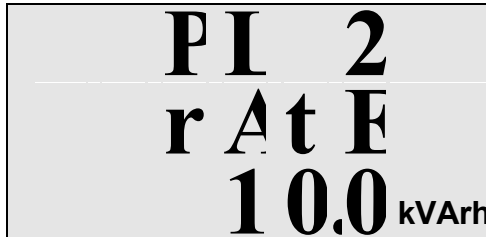

PL 2
rAtE
10.0 kVArh

Figure 4.3 Setting The Pulse Output #2 Rate

Press Δ to increase the Pulse Output Rate by a factor of 10.

Press ∇ to decrease the Pulse Output Rate by a factor of 10.

Press ? and hold for 2 seconds when done.

Programming

4.7 Setting The Ampere/Voltage Demand Period

The averaging period used in calculation of Ampere and Voltage Rolling Demand (ref. Section 2.1.2) may be set in the range 10-2500 seconds (steps of 10s). This period may be selected to set a convenient filter for short term fluctuations in input power, as required.

During programming, the Average Period is displayed in seconds.



Figure 4.4 Setting Ampere/Voltage Demand Period

Press Δ to increase the Averaging Period by 10 seconds.

Press ∇ to decrease the Averaging Period by 10 seconds.

Press ? and hold for 2 seconds when done.

4.8 Setting The kW Rolling Average Period

The averaging period used in calculation of kW Rolling Demand (ref. Section 2.1.2) may be set in the range 1-60 minutes. This period may be selected to match specific standards, or to set a convenient filter for short term fluctuations in input power, as required.

During programming, the Average Period is displayed in minutes.



Figure 4.5 Setting kW Rolling Demand Period

Press Δ to increase the Averaging Period by 1 minute.

Press ∇ to decrease the Averaging Period by 1 minute.

Press ? and hold for 2 seconds when done.

5. Options Module

5.1 Description

A range of retro-fit options modules are available for the MultiCube. These provide additional features to the meter such as serial communications, analogue outputs, alarms etc. A single options module may be mounted to the rear of the MultiCube as shown.

For detailed information on individual options modules refer to the separate Instruction manual.

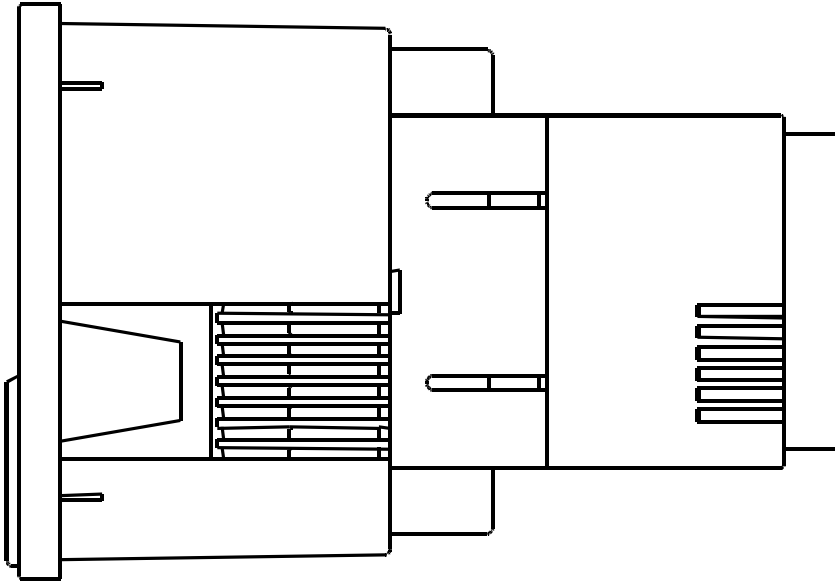

Figure 5.1 Options Module Attached to MultiCube

6. Specification

Inputs	
System	3-Phase 3 or 4 Wire Unbalanced Load
Voltage	Vb. 230 / 400 Volt. 3-Phase 3 or 4 Wire Vb. 63 / 110 Volt optional Vb. 120 / 208 Volt optional
Current	Ib 5 Amp from external current transformers (CTs) Ib 1 Amp optional Fully Isolated (2.5kV each phase)
Measurement Range Voltage Current	20% to 120% 0.5% to 120%
Frequency Range Fundamental Harmonics	45 to 65Hz Up to 20th harmonic
Input Loading Voltage Current	Less than 0.1 VA per phase Less than 0.1 VA per phase
Overloads Voltage Current	x2 for 2 seconds maximum x40 for 0.5 seconds maximum

Auxiliary Supply	
Standard	230 Volt 50/60Hz $\pm 15\%$
Options	110 Volt 50/60Hz $\pm 15\%$. (Others to order)
Load	5 VA Maximum

Specification

Accuracy	
Phase Current	0.2% Ib (1.0% Rdg. 0.05 Ib ≤ I _{ph} ≤ 1.2 Ib) ±1 digit.
Neutral Current	0.6% Ib (2.0% Rdg. 0.05 Ib ≤ I _n ≤ 1.2 Ib) ±1 digit.
Phase Voltage	0.2% Vb (1.0% Rdg. 0.2 Vb ≤ V _{ph} ≤ 1.2 Vb) ±1 digit.
Line-Line Voltage	0.3% Vb (1.0% Rdg. 0.2 Vb ≤ V _{LL} ≤ 1.2 Vb) ±1 digit.
Phase Watts	0.4% FS (1.0% Rdg. 0.05FS ≤ P ≤ 1.2FS) ±1 digit.
Phase VA	0.6% FS (1.5% Rdg. 0.05FS ≤ Q ≤ 1.2FS) ±1 digit.
Phase var	0.8% FS (2.0% Rdg. 0.05FS ≤ S ≤ 1.2FS) ±1 digit.
Phase PF	± 0.2 Degrees
System Watts	0.6% FS (1.0% Rdg. 0.05FS ≤ P ≤ 1.2FS) ±1 digit.
System VA	1.0% FS (1.5% Rdg. 0.05FS ≤ Q ≤ 1.2FS) ±1 digit.
System var	1.5% FS (2.0% Rdg. 0.05FS ≤ S ≤ 1.2FS) ±1 digit.
System PF	± 0.2 Degrees
Frequency	±0.05Hz. 45Hz ≤ F ≤ 65Hz
Wh Register	Class 1.0 EN 61036
VAh Register	Class 2.0
varh Registers	Class 2.0 IEC 1268
Timebase	Better than 100ppm

Display	
Display Type	Custom, supertwist, LCD with LED backlight
Data Retention	10 years minimum Stores energy registers, user settings, and peaks
Display Format	3 Lines 12mm digits + 3.8mm custom legends
Display Update	1 second

Digital (Pulse) Outputs	
Function	1 pulse / energy unit (Output #1=N Wh, Output #2=N varh)
Scaling	Settable 1, 10 or 100 counts of associated register
Pulse Period	100ms. (2ms Rise, 2ms Fall)
Type	N/O Volt free contact. Optically isolated BiFET
Contacts	100mA AC/DC max, 100V AC/DC max
Isolation	2.5kV (50V #1 to #2)

General	
Temperature	
Operating	-10 deg C to +65 deg C
Storage	-25 deg C to +70 deg C
Environment	IP40
Humidity	<75% non-condensing

Specification

Mechanical	
Enclosure	DIN 96mm x 96mm Mablex ULV94-V-O
Dimensions	96mm x 96mm x 80mm (72mm behind panel) 130mm behind panel with options unit fitted
Weight	Approx. 400g
Terminals	Rising Cage. 4.0mm ² cable max

Northern Design (Electronics) Ltd,
228 Bolton Road, Bradford,
West Yorkshire, BD3 0QW, England.
Telephone: +44 (0) 1274 729533
Fax: +44 (0) 1274 721074
Email: sales@ndmeter.co.uk
Or: support@ndmeter.co.uk
Copyright © Northern Design 2000

