

PowerRail350V Operating Manual

Current Sensor Inputs

August 2010



1 Safety

This instruction sheet gives details of safe installation and operation of the *PowerRail350V* electricity meter. Safety may be impaired if the instructions are not followed. Labels on each meter give details of equipment ratings for safe operation. Take time to examine all labels before commencing installation. Safety symbols on the meter have specific meanings.



Refer To User Manual

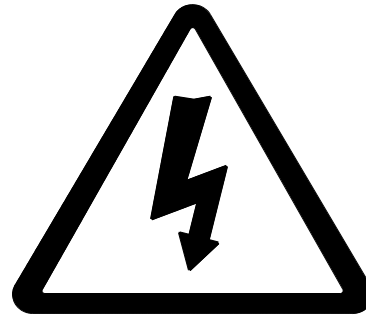

Risk of Electric Shock

WARNING

The meter contains no user serviceable parts. Installation and commissioning should only be carried out by qualified personnel

WARNING

Risk of Electric Shock

Isolate all inputs and supplies to the meter before connecting the current sensors on the load cables or wiring the sensors to the meter.

Further information is available at <http://www.ndmeter.co.uk>.

2 Operation

2.1 Energy Displays

Press  to select kWh kvarh and Hours Run display pages.



Active Energy Register





Hours Run



Reactive Energy Register^(Note 1)

The Hours Run register accumulates the total time during which the average 3-phase load current exceeds a preset level. This is always displayed with a resolution of 0.1hour. The percentage level of (I1+I2+I3) at which the Hours Run register accumulates is user programmable from 1% to 100% of full scale current.

Press  and  together and hold for 2 seconds to reset the hours run register. Scaling of the energy registers is set by the nominal input currents and voltages and remains constant during operation of the meter. Energy registers will each accumulate from zero to 99,999,999 then restart from zero.

2.2 Voltage Displays

Press  to select from the following displays;



Phase-n Voltages 1 - 3^(Note 1)



Line-Line Voltages 1 - 3^(Note 1)

2.3 Current Displays

Press  to select from the following displays;



Phase 1 - 3 Current

Operation

2.4 Power Displays

Press  to select from the following displays;



System Active Power



Frequency. Hz (Phase 1 voltage)



System Power Factor (C=Capacitive)^(Note 1)



Phase 1-3 Active Power^(Note 1)



Phase 1-3 Power Factor (C=Capacitive)^(Note 1)

NOTE 1: Some display pages are removed in **Balanced Voltage Mode** (Refer to section 3.7).

2.5 Pulse Outputs

Two isolated pulse outputs are provided for connection to external systems such as Building Energy Management Systems (BEMS), data loggers, remote counters etc. Pulse 1 is associated with the active energy (kWh) register and Pulse 2 with the reactive energy (kvarh) register. A single pulse occurs for each unit of energy on the display (eg 1 pulse per 0.1kWh). The pulse rate (amount of energy associated with each pulse) and pulse length may be set to suit the external system.

2.5.1 Pulse LEDs

Light emitting diodes (LEDs) on the front panel of the instrument remain ON during each associated output pulse.



Pulse Output Indicators

3 Programming

3.1 Programming Menu

To enter programming mode:



Hold  and  together for 5 Seconds.

A **Security Code** may be required before changes to programmed parameters are allowed. This is only required if a **Security Code** greater than zero is set via serial communications. This is then stored in non-volatile memory during power interruptions.



4-Digit Security Code



To Enter A Security Code:

Press  or  to change each digit. (Lowest significant digit first).

Press  to select next most significant digit.

When a valid code is input the programming menu is displayed.

To change a Programmable Value:

Press  or  until the required value is set.

To Move to The Next Setting:

Press  until the next page in the list is displayed. Parameters are set in the following order:

Program Menu Pages



Current Sensor Primary



Nominal Line-Line V (or PT Primary)



Output Pulse Rate



Pulse On Time



Pulse Output Test

The LCD display shows the text 'Hr' followed by the number '20' in a large, black, segmented font on a light green background.

Hours Run Trip Point (Percent Amps)

The LCD display shows the text 'true 3PH' in a large, black, segmented font on a light green background.

Voltage Input Mode

The LCD display shows the text 'Auto rot' in a large, black, segmented font on a light green background.

CT Auto Rotation Mode

The LCD display shows the text 'Storing' in a large, black, segmented font on a light green background.

Changes Are Stored to Non-Volatile Memory

After the last parameter is set the new values are stored and the meter continues to measure with the new settings.

3.2 Current Sensor Type Selection (CT)

Current sensor types are selected from a table of preferred types identified by their nominal primary current rating. The following types may be selected.

5, 50, 100, 150, 400, 800.

Note: Current sensors **MUST** be from the *PowerRail350V* range of input devices supplied by the manufacturer. Use of other sensors may affect accuracy & safety

3.3 Nominal Line-Line Voltage Selection (Un)

The nominal line-line voltage of the measured supply system may be programmed.



For systems without potential transformers (PTs) this should be the same as the nominal input of the meter as specified on the rating label (e.g. 400V).

For systems with PTs fitted this should match the nominal primary rating of the PT. The preferred values are:

11, 40, 48, 100, 110, 208, 400, 480, 600, 800, 1000, 1100, 2200, 3300, 4000, 4400, 5000, 7500, 10000, 11000, 15000, 22000, 25000, 33000, 40000, 44000, 55000

3.3.1 Fine Adjust

Fine Adjust Mode allows values other than those provided by the default tables to be set. To enter/exit *Fine Adjust Mode*:

Hold  and  together for 2 Seconds while setting *Un*. *Fine Adjust Mode* is indicated by a decimal point after "Un".

3.4 Pulse Rate Selection Table (Counts)

1, 2, 5, 10, 100, 1000



3.5 Pulse On-Time Selection Table

100ms ,200ms, 500ms, 1s, 2s, 3s, 5s, 10s, 20s

3.6 Pulse Output Test

This feature allows the pulse output hardware and external system connections to be commissioned without a measured load. The LCD shows **Pto** (off) and **Ptr** (run) and the number of test pulses. The test pulse rate is set automatically dependant on the programmed pulse length (maximum 0.5Hz).

Press  to start/stop the test pulses on both outputs.

Press  and  together to stop the test pulses and simultaneously reset the test counter.

3.7 Voltage Input Mode Selection

In “**Balance Voltage Mode**” the **PowerRail350** may be connected to a single voltage source in place of the three phases normally required for full accuracy measurement.

When **Balanced Voltage Mode** is enabled the voltage measured on phase 1 is copied to phases 2 & 3 and all three power-factors are assumed to be unity (1.00). In this mode, the voltage connected to phase 1 on the meter may be fed from any of the 3-Phase system voltages.

This connection is valid for loads with a near unity power-factor (PF=0.95 equates to an error of 5%) and balanced 3-Phase voltages.

The combination of **Split Core Current Sensors** and **Balanced Voltage Mode** allows for rapid commissioning where access cannot be made to 3-Phase terminations. At a later date when access is possible, for example during planned maintenance, the meter may be connected safely to the 3-Phase voltages and **Balanced Voltage Mode** de-selected.

Press  or  to toggle between **Balanced Voltage Mode** and **True 3-Phase Measurement Mode**.



True 3-Phase Measurement Mode



Balanced Voltage Mode

In **Balance Voltage Mode** some display menu pages are removed as they have little or no meaning and voltage is displayed as:



Voltage Display in Balanced Voltage Mode

Single Phase kW, Power Factor and kvarh displays are removed while **Balanced Voltage Mode** is enabled.

3.8 CT Auto Rotation Mode

When “**CT Auto Rotation Mode**” is selected, the orientation of each **Current Transformer (CT)** on its respective cable becomes irrelevant. It is therefore possible to pass the cable through the centre of the CT in either direction. In this mode current direction is ignored and all power is assumed to be feeding a load (import).

When “**CT Auto Rotation Mode**” is de-selected (“**True Rotation Mode**”) current direction is monitored and measurement of import and export power is provided.

In both modes it is essential to place each CT on the correct phase conductor associated with the relevant phase voltage: Therefore link **CT1 with V1**, **CT2 with V2**, **CT3 with V3**.

PowerRail350 meters are normally supplied with “**CT Auto Rotation Mode**” selected. In order to detect Positive and Negative power values in all four quadrants it is necessary to de-select “**CT Auto Rotation Mode**”.

In the programming Menu Press  or  to toggle between **CT Auto Rotation Mode** and **True Rotation Mode**.



CT Auto Rotation Mode



True Rotation Mode

NOTE: **CT Auto Rotation Mode** is not available when **Balanced Voltage Mode** is selected as all Power Factors are assumed to be unity and current phase and direction is ignored.

4 Display Scaling

The units, Wh, kWh or MWh and the position of the decimal point for the energy/power displays are automatically set dependant on the **CT** and **Un** settings for the meter.

The nominal 3-phase input for the meter is defined as:

$$W_{nom} = \sqrt{3} \times Un \times CT$$

Where: **Un** is the nominal Line-Line voltage or PT primary (10V - 55kV).
CT is the current sensor nominal primary (10A – 25kA)
Un and **CT** are set in programming mode.

The display pages are scaled as follows:

The display pages are scaled as follows:

CT	Amps Resolution
5A	0.01 A
50A	0.01 A
100 A	0.1 A
150A	0.1 A
400A	0.1 A
800A	1 A

Un	Volts Resolution
<= 90 V	0.01 V
<= 1200 V	0.1 V
<= 9,000 V	0.001 kV
> 9,000 V	0.01 kV

<i>W_{nom}</i>	kW/kvar Resolution	kWh/kvarh Resolution
< 243 W	0.1W (var)	0.001 kWh (kvarh)
< 2.43 kW	0.1W (var)	0.001 kWh (kvarh)
< 24.3 kW	0.001 kW (kvar)	0.01 kWh (kvarh)
< 243 kW	0.01 kW (kvar)	0.1 kWh (kvarh)
< 2.43 MW	0.1 kW (kvar)	1 kWh (kvarh)
< 24.3 MW	1 kW (kvar)	0.01 MWh (Mvarh)
< 243 MW	0.01 MW (Mvar)	0.1 MWh (Mvarh)
> 243 MW	0.1 MW (Mvar)	1 MWh (Mvarh)

5 Installation

5.1 Mounting On A Rail

The **PowerRail350V** conforms to DIN 43880, 6-Module Wide. The unit is therefore compatible with a number of standard distribution systems with 45mm cut-outs. The meter should be mounted on a 35mm symmetrical ("Top-Hat") DIN rail of minimum length 106mm.

5.2 Pulse Output Connection

The pulse outputs take the form of isolated volt free normally open contact pairs.

The contacts are isolated from all other circuits (2.5kV / 1 minute) and at 50V from pulse1 to pulse 2.

The pulses can be used as an input to a remote counter, pulse logger, building energy management system etc.

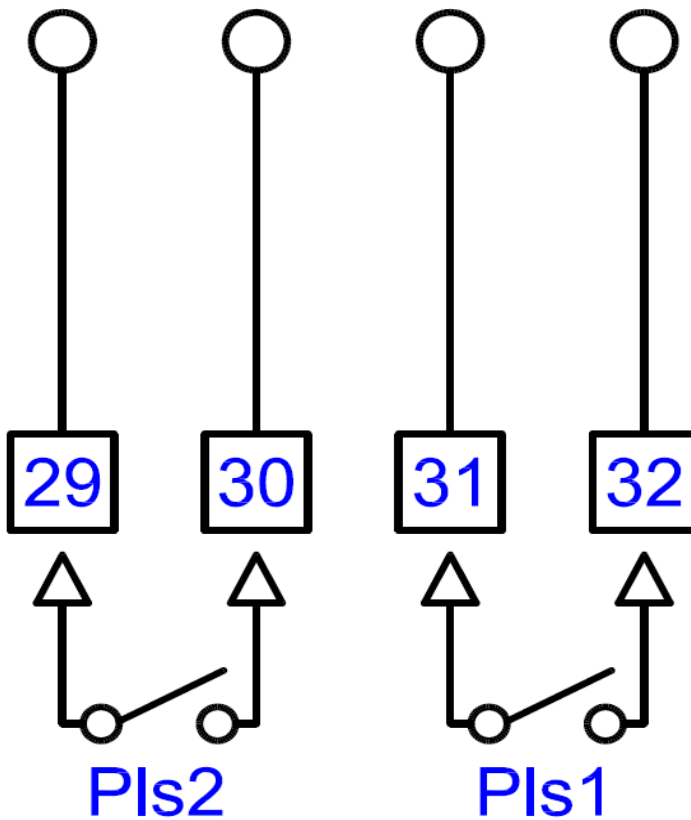

Pulse Output Connections

5.3 Using Current Sensors

WARNING **Risk of Electric Shock**

Isolate all inputs and supplies to the meter before connecting the current sensors on the load cables or wiring the sensors to the meter.

5.3.1 Current Sensor Polarity

If measurement of positive and negative power is required (**True CT Rotation Mode**) the current sensors MUST be placed on the load cable with the correct polarity. Refer to Section 3.8 for more information about setting the CT Rotation Mode.

The following diagram shows how each device is fitted on the cable for correct operation:

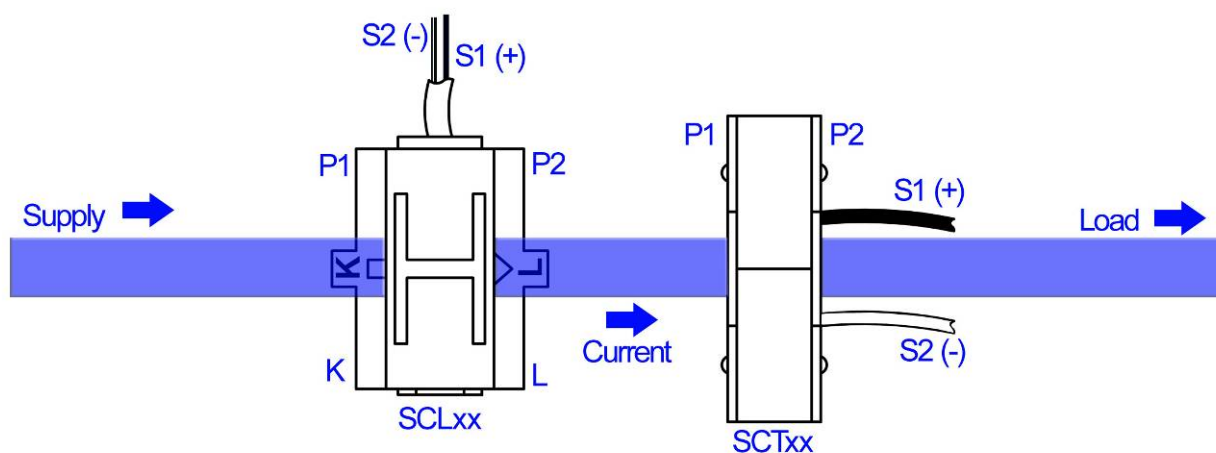

NOTE: If a current sensor is placed on the cable in the opposite orientation the associated phase kW reading will be negative.

The secondary cables also require wiring with correct polarity. The white cable (or black/white) is the negative and should be connected to S2 or CT- on the meter. The black cable is the positive and should be connected to S1 or CT+ on the meter.

NOTES:

- The output from these current sensors is a low voltage. It is safe to leave these outputs open-circuit if not connected to a meter.
- The output connections from these current sensors must be individually wired direct to the meter and must not be earthed or connected to any other circuit.
- If the sensor secondary cables require extending care must be taken to avoid pickup of electrical interference. With suitable low capacitance screened cables, the cable can be extended to 100m or more.
- Examples of suitable cables include Belden 9841, Alpha 6412 and equivalents; also multi-pair versions of these cables.
This cable must have an insulation rating >250V.
- Current sensor polarity is irrelevant in **Auto CT Rotation Mode**. (refer to Section 3.8)

Installation

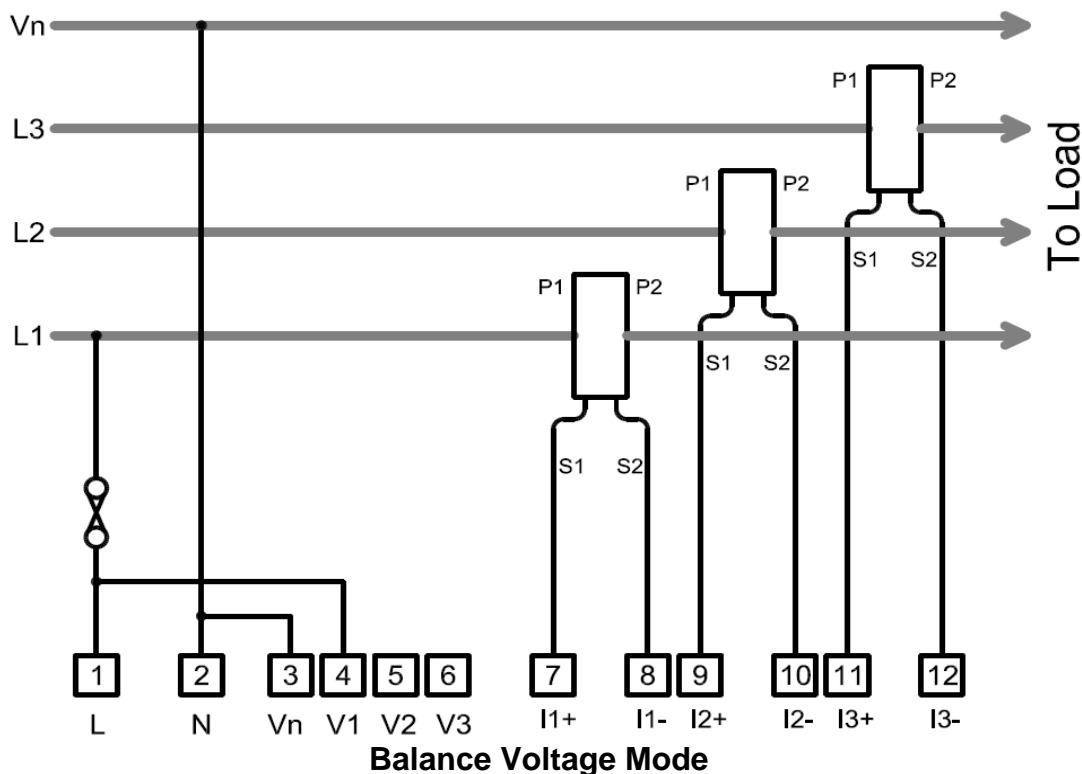

NOTE: In **Balanced Voltage Mode** L1, L2 or L3 may be used as the voltage input to V1 as phase is assumed to be zero in all measurements.

Balanced Voltage Mode must be selected in the programming Menu (Refer to Section 3.7) in order to obtain meaningful measurements.

WARNING

Ensure the supply connected to L-N (Aux Supply) and Vn-V1 (Voltage Input) is rated in accordance with the individual meter rating labels.

7 Specification

INPUTS	
System Voltage Un	3 Phase 3 or 4 Wire Unbalanced Load 400/230V. 3 Phase 3 or 4 Wire 110/63V, 120/240V & 208/120V optional. Others to order.
Current Sensors	
Output @ Nominal In	0.333Vac
Accuracy	±1% (0.1In – 1.2In)
ND SCL8-5	In = 5A; Max Cable = 8mm Dia. Phase Error <2.5° at 0.5In
ND SCL16-50	In = 50A; Max Cable = 16mm Dia. Phase Error <2.5° at 0.5In
ND SCL16-100	In = 100A Max Cable = 16mm Dia. Phase Error <2° at 0.5In
ND SCT19-150	In = 150A Max Cable = 19mm Dia. Phase Error <2° at 0.5In
ND SCT32-400	In = 400A; Max Cable = 32mm Dia. Phase Error <2° at 0.5In
ND SCT51-800	In = 800A; Max Cable = 51mm Dia. Phase Error <2° at 0.5In
Enclosures	UL94V-0
Insulation	>300Vrms, CAT III
Environment	Indoor use only (Altitude < 2000m)
Measurement Range	Voltage 50% to 120%
Frequency Range	Current 0.2% to 120%
	Fundamental 45 to 65Hz
	Harmonics Up to 30th harmonic at 50Hz Individual to the 15th
Voltage Burden	<0.1VA per phase
Overload	Voltage x4 for 1 hour
	Current
	SCL x10 for 1min
	SCT19 200A Continuous
	SCT32 800A Continuous
	SCT51 2000A Continuous
DISPLAY	
Type	Custom, Supertwist, LCD with LED backlight
Data Retention	10 years min. Stores kWh & Meter set-up
Format	8 x 6.66mm high digits with DPs & 3.2mm legends
Scaling	Direct reading. User programmable CT & VT CT Primary programmable from 5A to 25kA VT primary programmable from 11V to 55kV
Legends	Wh, kWh, MWh etc. depending on user settings
AUXILIARY SUPPLY	
Standard	230V 50/60 Hz ±15%
Options	110V 50/60 Hz ±15%
Load	2VA max.
Overload	x1.2 continuous
METER ACCURACY All errors ± 1 digit	
kWh	Better than Class 1 per EN 62053-21 & BS 8431
Kvarh	Better than Class 2 per EN 62053-23 & BS 8431
kW & kVA	Better than Class 0.25 IEC 60688
kvar	Better than Class 0.5 IEC 60688
Amps & Volts	Class 0.1 IEC 60688 (0.01In – 1.2In or 0.1Un – 1.2Un)
PF	±0.2° (0.05In – 1.2In and 0.2Un – 1.2Un)
Neutral Current	Class 0.5 IEC 60688 (0.05In – 1.2In)

OVERALL METERING ACCURACY		
ND SCL8-5	5 Amp	Better than Class 2 Meter with Class 1 CTs
ND SCL16-50	50 Amp	Better than Class 1 Meter with Class 1 CTs
ND SCL16-100	100 Amp	Better than Class 1 Meter with Class 1 CTs
ND SCT19-150	150 Amp	Better than Class 1 Meter with Class 1 CTs
ND SCT32-400	400 Amp	Better than Class 1 Meter with Class 1 CTs
ND SCT51-800	800 Amp	Better than Class 1 Meter with Class 1 CTs
PULSE OUTPUTS		
Function		1 Pulse per unit of energy
Scaling		Settable between 1 & 1000 counts of kWh register
Pulse Period		0.1 sec. default; Settable between 0.1 and 20 sec
Rise & Fall Time		< 2.0ms
Type		N/O Volt free contact. Optically isolated BiFET
Contacts		100mA ac/dc max., 100V ac/dc max.
Isolation		2.5kV 50Hz 1 minute
MODBUS® Serial Comms		
Bus Type		RS485 2 wire + 0v. ½ Duplex, ¼ unit load
Protocol		MODBUS® RTU with 16 bit CRC
Baud Rate		4800, 9600 or 19,200 User settable
Address		1 – 247 User settable
Latency		Reply within 250ms max.
Command Rate		New command within 5ms of previous one
GENERAL		
Temperature		Operating -10°C to +65°C Storage -25°C to +70°C
Humidity		< 75% non-condensing
Environment		IP54 standard, IP65 optional
MECHANICAL		
Terminals		Rising Cage. 4mm ² (12 AWG) cable max.
Enclosure		DIN 43880, 6-Modules Wide
Material		Noryl® with fire protection to UL94-V-O. Self extinguishing
Dimensions		106 x 90 x 58mm (Cut out 106 x 45mm)
Weight		~ 250 gms
SAFETY		
Conforms to		EN 61010-1 Installation Category III & BS 8431

E. & O. E.

© Northern Design (Electronics) Ltd, March 2008